



SUNSYS PCS² IM

Power Conversion System and Storage
with Islanding Mode
from 33 to 200 kVA

EN

CONTENTS

1. CERTIFICATE AND CONDITIONS OF WARRANTY	5
2. SAFETY STANDARDS	6
2.1 DESCRIPTION OF SYMBOLS	7
2.2 ABBREVIATIONS	8
3. FOREWORD	9
4. SUNSYS PCS² RANGES	11
4.1 IEC VERSIONS	11
4.2 UL VERSIONS	11
5. ENVIRONMENTAL REQUIREMENTS AND HANDLING	12
5.1 ENVIRONMENTAL REQUIREMENTS	12
5.2 HANDLING	14
5.3 FLOOR ASSEMBLY	15
5.4 INSTALLATION	16
5.4.1 PROCEDURE FOR PCS ² IM 33 - 66 - 100 TR	16
5.4.2 PROCEDURE FOR PCS ² IM 132 - 200 TL	21
6. ELECTRICAL INSTALLATION	31
6.1 ELECTRICAL REQUIREMENTS	31
7. OVERVIEW	33
7.1 SWITCHES AND INTERFACES	33
7.2 DIAGRAM OF MAIN SYSTEM EXAMPLE FOR VERSION 100 TR	41
8. CONNECTIONS	42
8.1 INPUT CONNECTION	42
8.2 INSTRUCTIONS FOR SUNSYS PCS ² IM 200 TL	48
9. CONTROL PANEL	49
9.1 EXCEPTION FOR PCS ² IM 132 - 200 TL	50
9.2 CONVERTER STATE MACHINE	51
10. FIRST START-UP	52
11. MENU	55
11.1 DISPLAY OVERVIEW	55
11.2 MENU TREE	58
11.3 MENU DESCRIPTION	60
12. OPERATING PROCEDURES	62
12.1 SWITCHING ON	62
12.2 SWITCHING OFF	63
13. STANDARD FEATURES AND OPTIONS	64
13.1 SERIAL COMMUNICATION INTERFACE	64
13.2 MODBUS TCP INTERFACE	66
13.3 ADC CARD	67
13.4 SERIAL COMMUNICATION INTERFACE	68
13.5 SIGNAL CABLES ROUTE	69
14. WARNINGS AND TROUBLESHOOTING	70
15. PREVENTIVE MAINTENANCE	73
15.1 BATTERIES	73
15.2 FANS & CAPACITORS	73
16. SAFEGUARDING THE ENVIRONMENT	74
17. TECHNICAL SPECIFICATIONS	75

1. CERTIFICATE AND CONDITIONS OF WARRANTY

SOCOMEK warrants the SUPPLY against all proven defects or hidden defects in design and manufacture.

The period of warranty starts from the date of shipment and consists of 24 (twenty-four) months as from the date of commissioning of the SUPPLY and shall not exceed 27 (twenty-seven) months from the date of the dispatch.

For all cases, the CUSTOMER shall not be entitled to enforce the warranty unless it shall have fully paid for the SUPPLY.

The warranty of SOCOMEK shall be strictly limited to its SUPPLY and does not extend to the equipment within which the SUPPLY is integrated nor to the performance of such equipment. SOCOMEK's liability shall be limited, in its discretion, to the repair or replacement at its expense in its factory of all or part of the SUPPLY recognized as defective. As soon as the CUSTOMER has knowledge of the defect, it shall inform SOCOMEK in writing of the defects which it claims affect the SUPPLY, and shall supply all evidence thereof and indicate the use and the conditions of use of the SUPPLY. SOCOMEK reserves the right to modify the SUPPLY in order to satisfy the implementation of its warranty. The repair, replacement or modification of all or part of the SUPPLY during the period of warranty shall not have the effect of prolonging the duration thereof. Defective items replaced free of charge shall be made available to SOCOMEK and shall become its property. Items invoiced as appropriate to the CUSTOMER shall be warranted 3 (three) months in normal conditions of use.

The warranty shall be excluded:

- a) In the event that the defect is due to the material supplied by the CUSTOMER, or due to a design imposed by it.
- b) In the event of damage or accident due to the transport or arising from the negligence, defective installation, supervision or maintenance by the CUSTOMER or a third party.
- c) In the event of use, installation or storage of the SUPPLY in abnormal conditions or conditions not in compliance with recommendations of SOCOMEK.
- d) If the CUSTOMER has carried out or has had carried out any changes, adjustments or repairs to the SUPPLY without the express agreement of SOCOMEK.
- e) In the event of damage arising from events of frustration or force majeure, or due to the fault of the CUSTOMER or of a third party.













The warranty does not cover the replacement or repair of items which are due to normal wear and tear of the SUPPLY.

SOCOMEK retains the full and exclusive ownership rights to this document. Only a personal entitlement to use the document for the application indicated by SOCOMEK is granted to the recipient of this document. The reproduction, modification, distribution of this document, either partially or wholly and in any manner, is strictly prohibited except upon Socomec's express prior written consent.

This document is not a specification. SOCOMEK reserves the right to make any changes to the information provided without prior notice.

2. SAFETY STANDARDS

This user manual specifies installation and maintenance procedures, technical data and safety instructions for SOCOMEC products. For further information visit the Socomec website: www.socomec.com.

	NOTE! Any work carried out on the equipment must be performed by skilled, qualified technicians.
	NOTE! Before carrying out any operations on the SUNSYS PCS ² IM read the installation and operating manual carefully. Keep this manual safe for future reference.
	DANGER! Failure to observe safety standards could result in fatal accidents or serious injury, and damage equipment or the environment.
	CAUTION! If the unit is found to be damaged externally or internally, or any of the accessories are damaged or missing, contact SOCOMEC. Do not operate the unit if it has suffered a violent mechanical shock of any kind.
	NOTE! Install the unit in accordance with clearances in order to prevent access to handling devices and guarantee sufficient ventilation (refer to 'Environmental requirements' chapter).
	NOTE! Only use accessories recommended or sold by the manufacturer.
	NOTE! When the equipment is transferred from a cold to a warm place wait approx. two hours before putting the unit into operation.
	NOTE! When carrying out electrical installation, all standards applicable specified by the IEC and the electricity supplier must be observed. All national standards applicable to batteries must be observed. For further information refer to 'Technical specifications' chapter.
	DANGER! LIVE DEVICE! RISK OF ELECTRIC SHOCK: SUNSYS PCS² IM is connected to three separately protected power supplies: 1 DC cable - Battery power supply. 2 AC cable - Power from the mains network, supplied by the electricity company. 3 AC cable - Auxiliary power supply.
	DANGER! RISK OF ELECTRIC SHOCK! Before carrying out any operations on the unit (cleaning and maintenance performances, connection of appliances, etc.) disconnect all power sources.
	DANGER! LIVE DEVICE! RISK OF ELECTRIC SHOCK: Carry out the following steps before system maintenance: <ul style="list-style-type: none"> - Disconnect the batteries. - Disconnect the AC power supplies. - Disconnect the DC disconnection switches. - Make sure the cable is fixed in position securely. - Make sure the system cannot be restarted. - Make sure the electricity supply (AC and DC voltages) has been disconnected. - Cover or separate nearby live device units.
	DANGER! RISK OF ELECTRIC SHOCK! After disconnecting all power sources wait approx. 5 minutes for the complete discharge of the unit.
	CAUTION! RISK OF BURNS! During operation the casing can reach high temperatures. Do not touch the surfaces!

**NOTE!**

Any use other than the specified purpose will be considered improper. The manufacturer/supplier shall not be held responsible for damage resulting from this. Risk and responsibility lies with the system manager.

2.1 DESCRIPTION OF SYMBOLS

Comply with all internal and external precautions and warnings on labels and plates on the equipment.

Symbols	Description
	Protective earth terminal (PE).
	Authorised personnel only.
	No smoking.
	Risk of electric shock!
	Risk of explosion! Avoid short circuits!
	Read the user instructions carefully. Read the user manual before performing any operations.
	Wear protective gloves
	Wear safety shoes.
	Wear protective goggles.
	In the event of contact with the eyes, wash immediately with plenty of water and call a doctor. Call a doctor immediately in the event of accidents or illness.
	Do not dispose of in normal waste stream (symbol waste electrical and electronic equipment).

2.2 ABBREVIATIONS

For the purpose of this document, the following abbreviations are used:

BES	Battery Energy Storage
BMS	Battery Management System
EMC	Electro Magnetic Compatibility
EMS	Energy Management System
ESS	Energy Storage System
HMI	Human Machine Interface
IEC	International Electrotechnical Commission
IM	Islanding Mode
IMD	Insulation Monitoring Device
PCS	Power Conversion System
PE	Protective Earth
PMS	Power Management System
PV	Photovoltaic
SBMS	System BMS
SOC	State of Charge
SOH	State of Health
SPD	Surge Protection Device
THDI	Total Harmonic Distortion in Current
THDV	Total Harmonic Distortion in Voltage
TL	Transformer-less
TR	Transformer based

3. FOREWORD

Energy storage is the key solution to meeting the challenges of energy transition, using renewable energy and providing energy cost reductions for the following 4 main applications.

- **Behind-the-Meter Energy Storage:**

Reduce peak consumption and maximise PV energy self-consumption. SUNSYS PCS² (IM) can limit the impact of increases in the electricity retail price by supplying the load to cut peak demand (peak shaving), maximising PV energy self-consumption at building or community level. Any PV energy surplus is stored in the SUNSYS PCS² (IM) battery system. This stored energy is used later to supply the load.

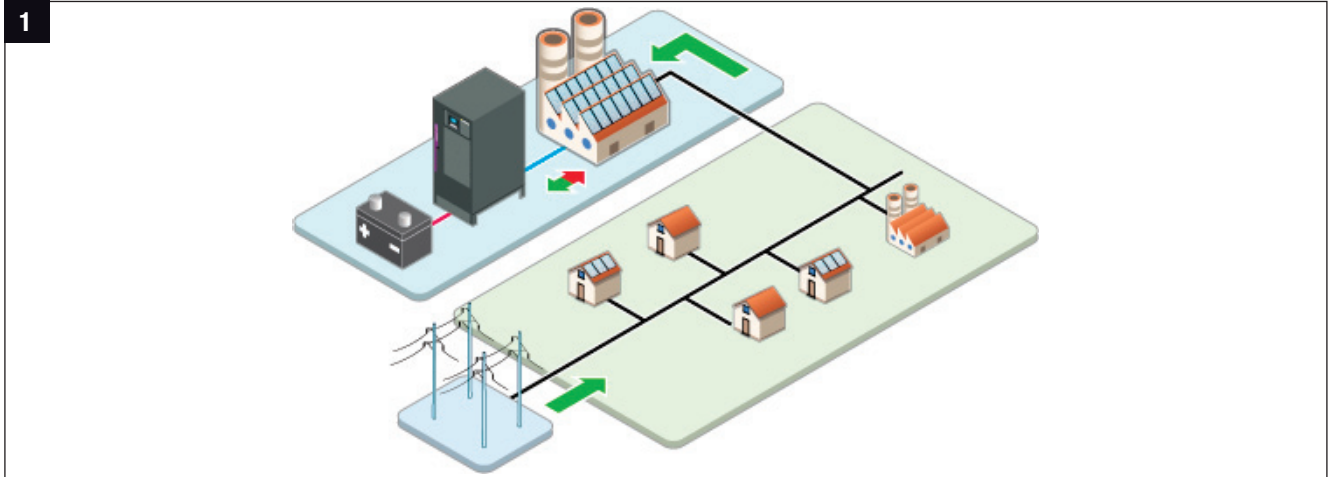

- **PV plants:**

Manage the intermittence of renewable energy production. SUNSYS PCS² (IM) ensures the production profile of an intermittent renewable energy plant by limiting production to a predefined value, injecting energy to compensate for solar variations, setting constant ramp-up or ramp-down.

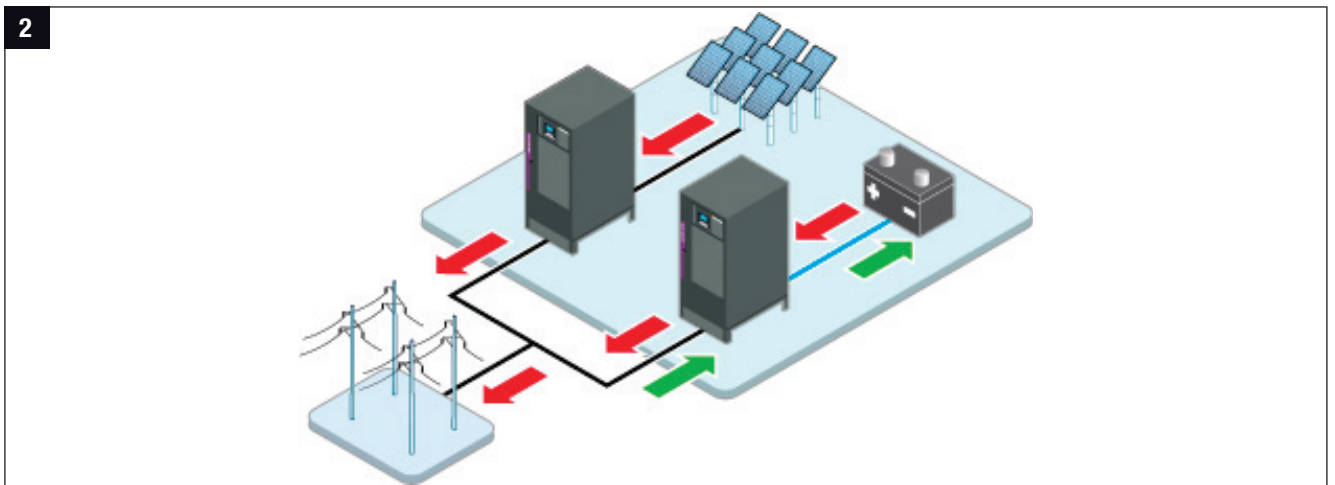

• **Grid support:**

Meet the challenge of demand-response energy balance. When directly connected to the grid, SUNSYS PCS² (IM) improves stability and management of grid operators thanks to voltage and frequency regulation, load shifting, peak shaving and ancillary services for grid support.

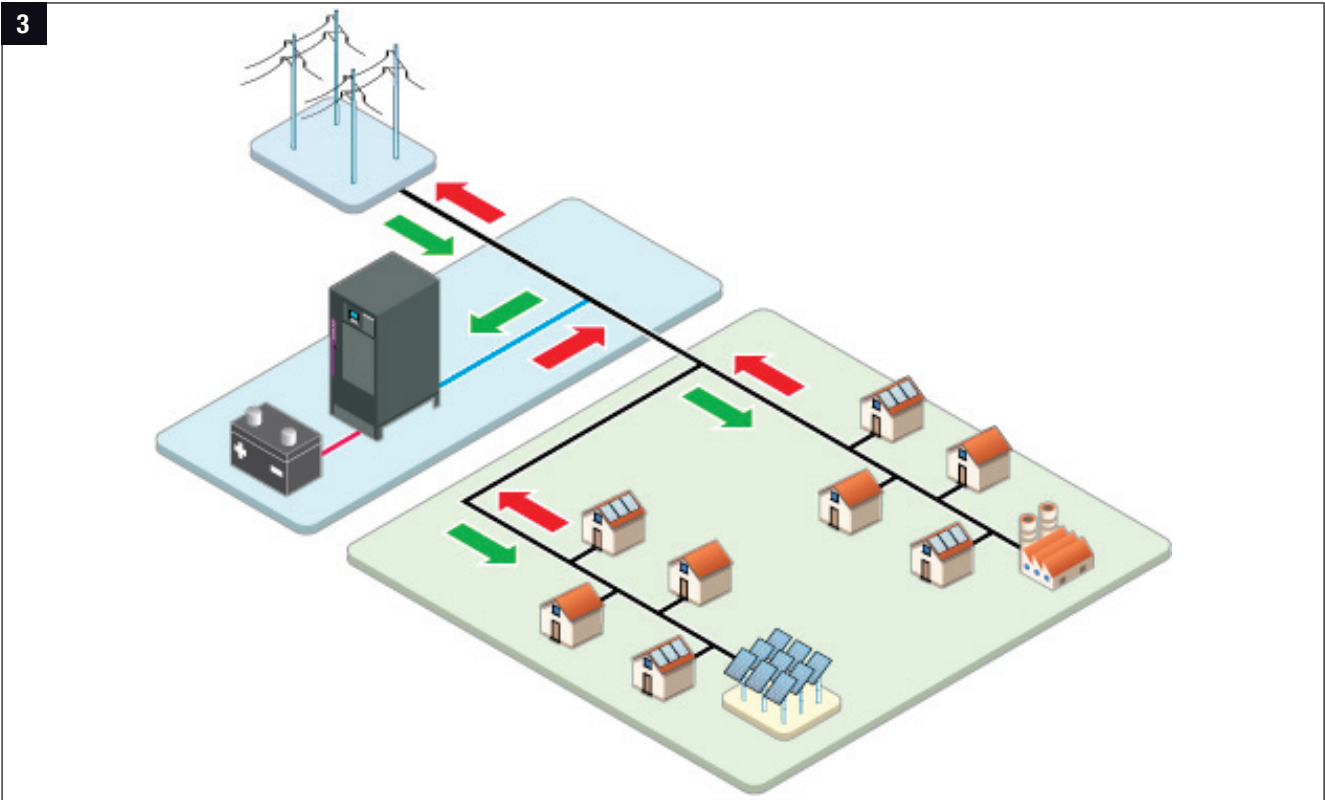

• **Microgrids:**



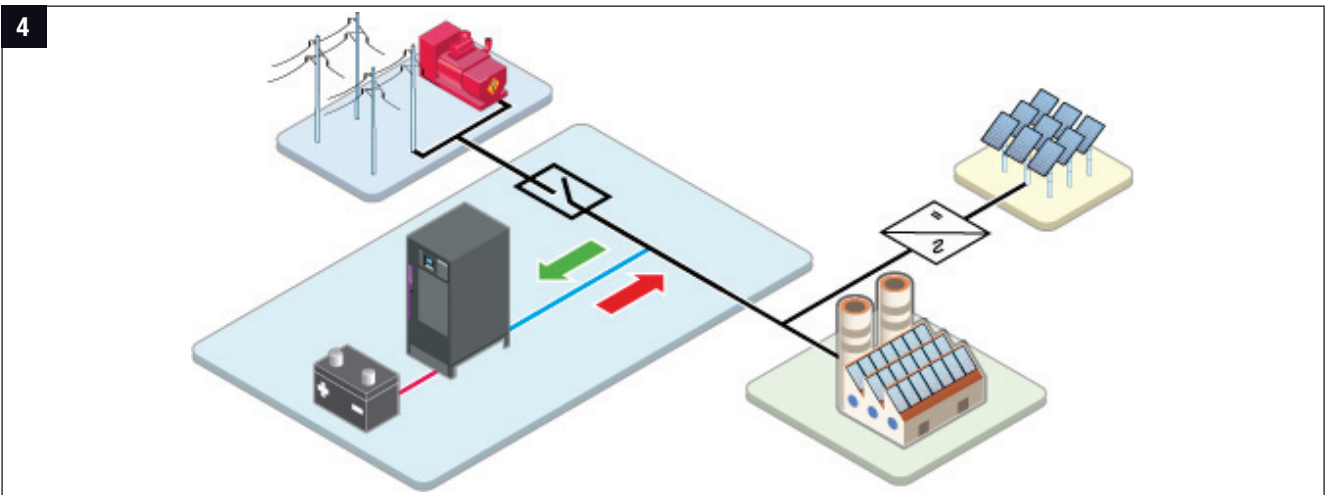

















Ensure energy availability and quality. The SUNSYS PCS² IM enables the microgrid to disconnect from the main grid and be electrically autonomous thanks to local generation (PV, Wind, Diesel generators, etc.).























To sum up:			
Products / Applications	On-Grid	On-Grid + Off-Grid	Pure Off-Grid
SUNSYS PCS ²	•		
SUNSYS PCS ² IM		•	•

4. SUNSYS PCS² RANGES

4.1 IEC VERSIONS

	SUNSYS PCS ²					SUNSYS PCS ² IM				
	33 kVA	66 kVA	100 kVA	132 kVA	200 kVA	33 kVA	66 kVA	100 kVA	132 kVA	200 kVA
Internal transformer (TR version)										
External transformer (TL version)										

4.2 UL VERSIONS

	SUNSYS PCS ²					SUNSYS PCS ² IM				
	33 kVA	66 kVA	100 kVA	132 kVA	200 kVA	33 kVA	66 kVA	100 kVA	132 kVA	200 kVA
Internal transformer (TR version)										
External transformer (TL version)										

5. ENVIRONMENTAL REQUIREMENTS AND HANDLING

5.1 ENVIRONMENTAL REQUIREMENTS

Install the unit in an equipment room.

The room must be:

- of a suitable size;
- free from conductive, inflammable and corrosive items;
- not exposed directly to sunlight.

The floor must support the weight of the unit and guarantee its stability. The unit is designed for indoor rooms only. For information regarding ambient temperature, dimensions and weights refer to 'Technical specifications' chapter. To position the unit correctly see the diagrams below.

ROOM POSITIONING

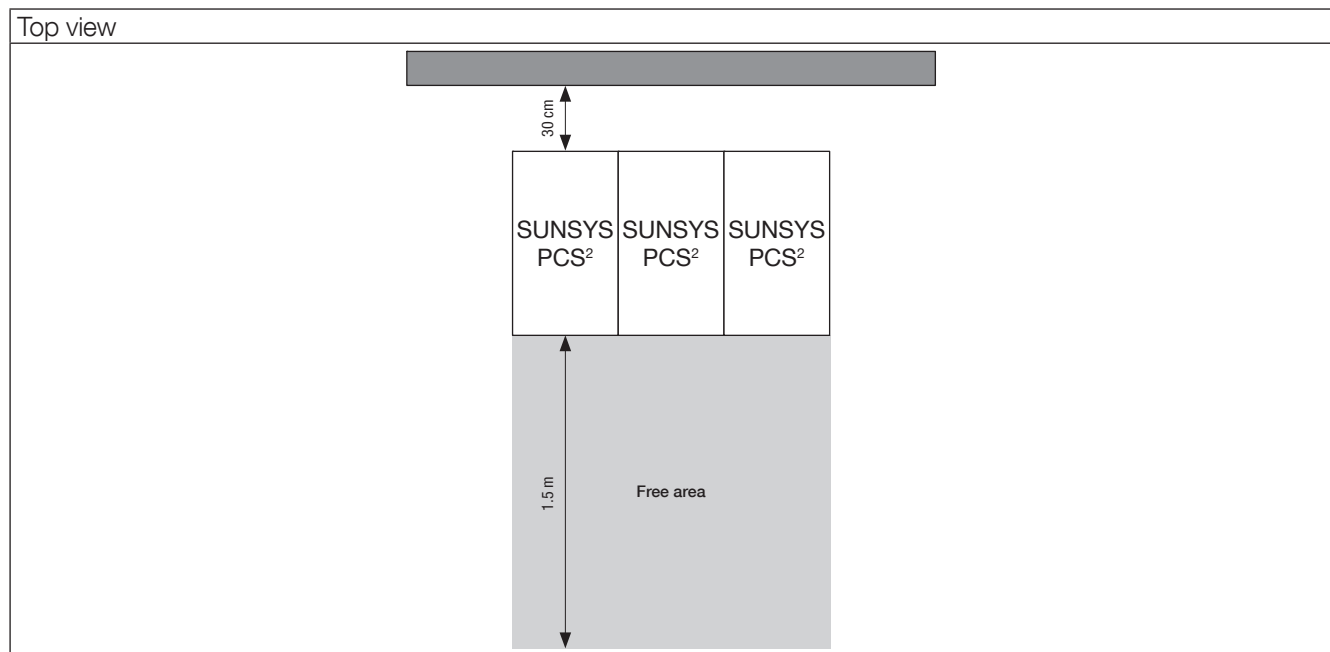

SPACING-AIR FREE

To ensure the full unit power up to 40°C ambient temperature, observe the following minimum distances:

- rear space: 30 cm.
- above space: 45 cm.

This distance can be reduced depending on:

- the maximum ambient temperature accepted (Full load conditions).

Distance from the rear wall	Space above the top panel	Ambient temperature
30 cm	45 cm	40 °C
	25 cm	35 °C
20 cm	45 cm	35 °C
	25 cm	30 °C
10 cm	45 cm	25 °C
	25 cm	

- the maximum power required from the load (at 40 °C ambient temperature).

Distance from the rear wall	Space above the top panel	Power
30 cm	45 cm	100%
	25 cm	90%
20 cm	45 cm	90%
	25 cm	80%
10 cm	45 cm	75%
	25 cm	75%

SPACING-AIR FLOW

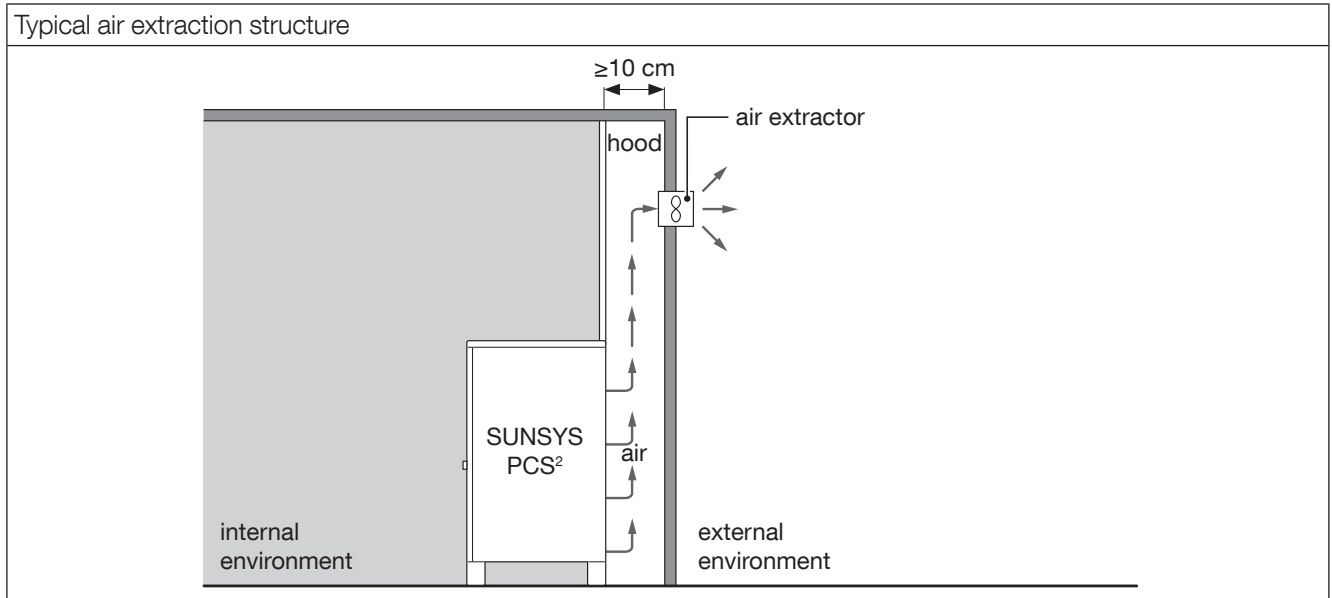

Minimum air extractor flow ⁽¹⁾	
Models	Minimum extraction flow
33 TR	600 m ³ /h
66 TR	1200 m ³ /h
100 TR	1800 m ³ /h
132 TL	1780 m ³ /h
200 TL	2700 m ³ /h

1. SUNSYS PCS² at a distance of 10 cm from the rear wall (40 °C ambient temperature and full load).





	<p>NOTE: the hood must prevent air losses and enable the removal of the SUNSYS PCS²'s top panel for maintenance.</p>
--	--

CABINET LAYOUT



5.2 HANDLING

- The packaging guarantees the stability of the unit during shipping and physical transfer.
- The unit must remain in a vertical position during all shipping and handling operations.
- Ensure that the floor is strong enough to support the weight of the unit.
- Carry the packaged unit as close as possible to the installation site.

	<p>WARNING! HEAVY WEIGHT! Move the unit using a fork lift truck taking the utmost caution at all times.</p>
	<p>The unit MUST be handled by at least two people. The people MUST take position at the sides of the PCS with respect to the direction of movement.</p>
	<p>Do not move the unit by putting pressure on the front door.</p>
	<p>When moving the unit on even slightly sloping surfaces, use the locking equipment and braking devices to ensure that the unit does not fall over.</p>
	<p>WARNING! The following instructions must be carried out prior to moving the unit (after initial positioning). Failure to heed this warning could result in the unit falling over, equipment damage, injury and even death.</p>

5.3 FLOOR ASSEMBLY

- PCS² range 33 - 66 - 100 TR/TL:

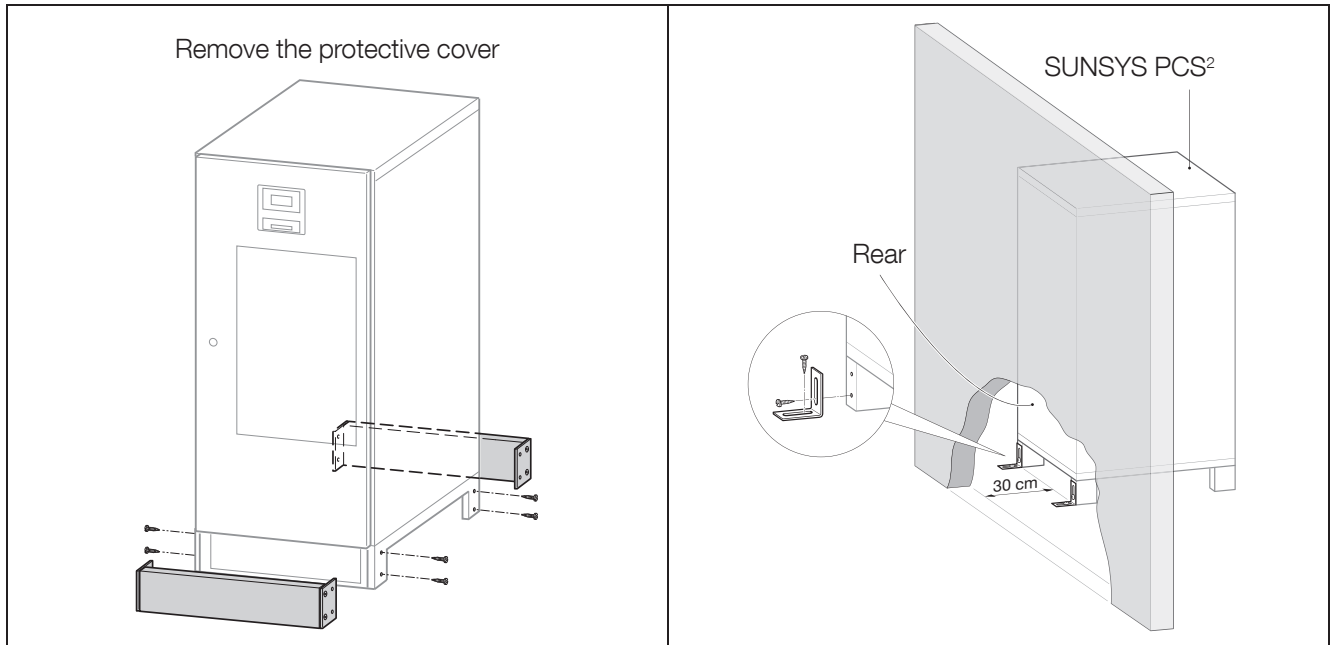



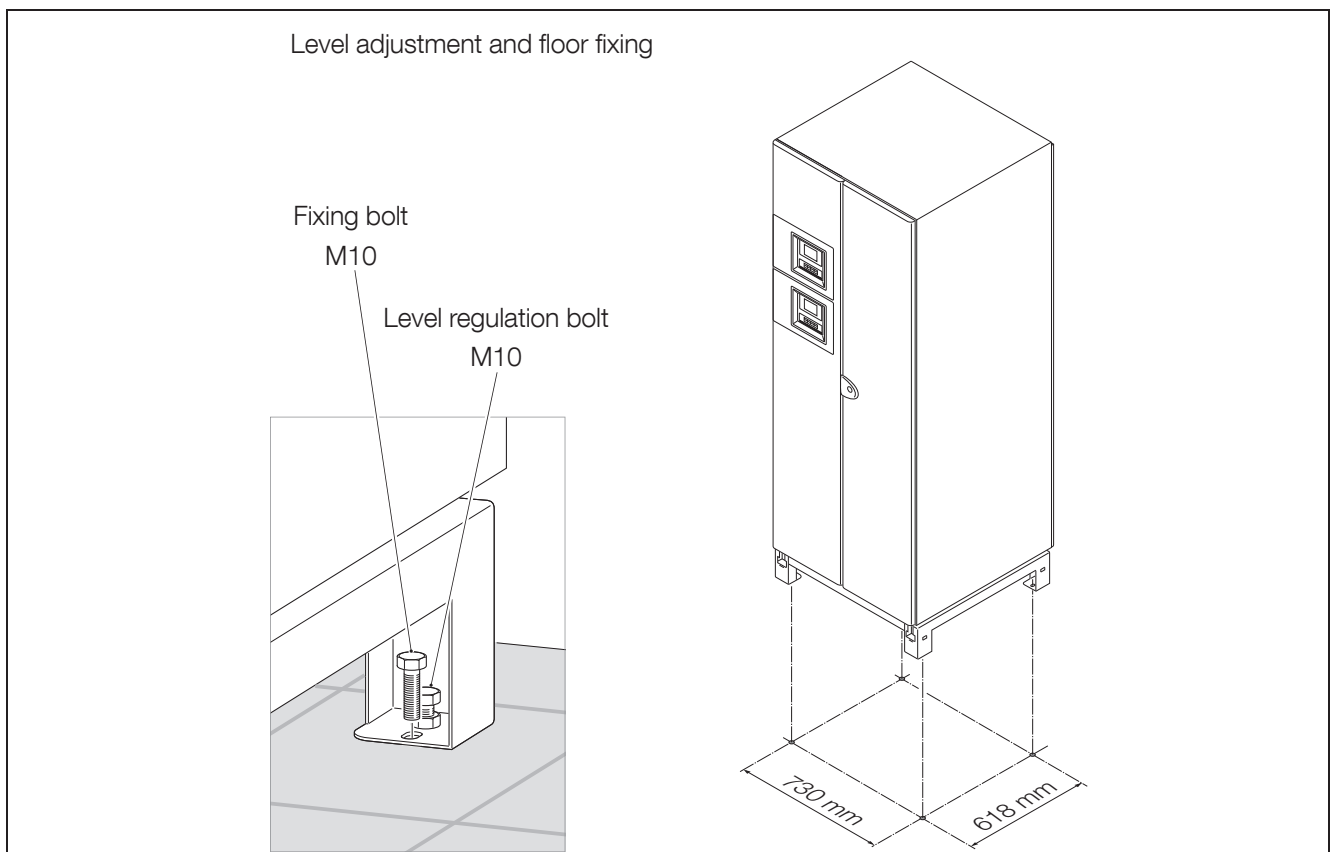

- PCS² IM 132 - 200 TL:



5.4 INSTALLATION

POWER MODULE INSERTION

	WARNING: before installing the module ensure that there is no voltage.
	NOTE: the module must be handled by at least two people (34.5 kg / 76 lb).
	WARNING! RISK OF TIPPING OVER: before carrying out any operations, ensure the SUNSYS PCS ² IM is secured at the feet.
	WARNING! RISK OF TIPPING OVER: the modules must be inserted from the bottom upwards and removed from the top downwards to ensure the unit remains stable.
	WARNING: the modules have to be moved individually. Never handle more than one module.

5.4.1 PROCEDURE FOR PCS² IM 33 - 66 - 100 TR

- Open the door with the appropriate key.

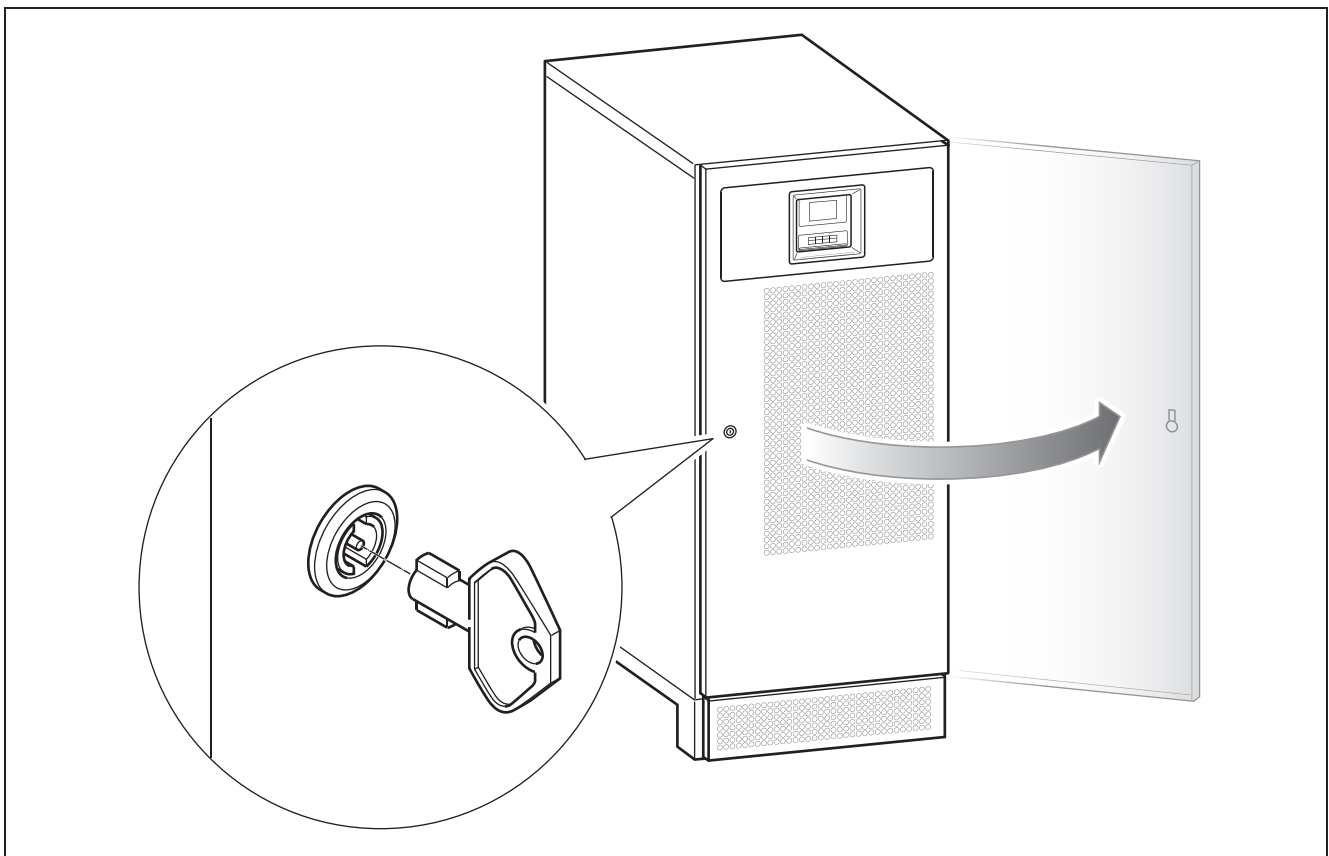

- Position the cables in the hose clamp to enable correct module insertion.

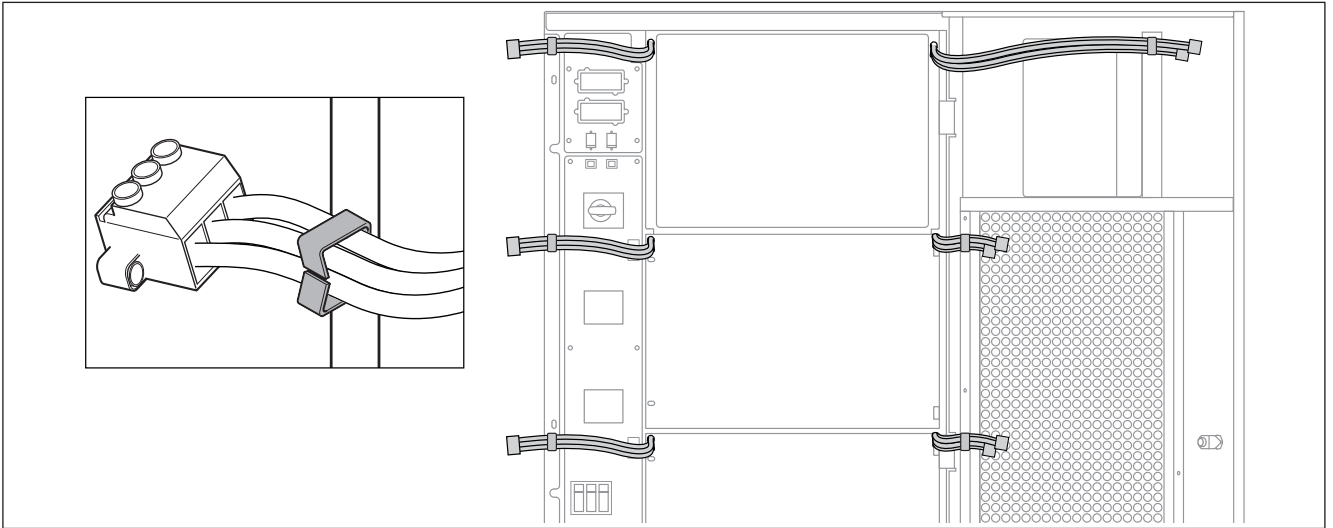

- Remove the Lexan protection on the connectors.

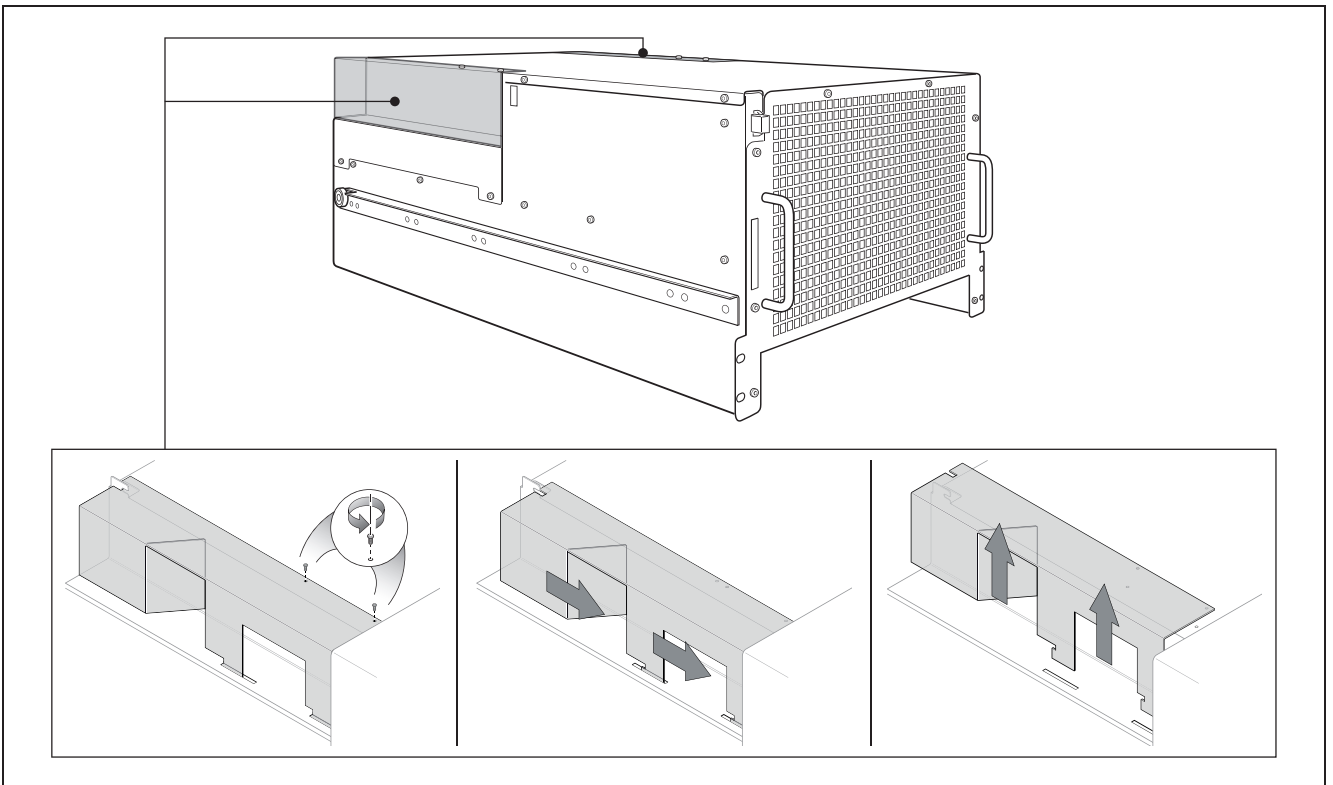

- Place the module on the guides and insert it up to the limit starting by the lower one.



In order to ensure the safety of installers, installers shall be at least two people to process the installation (34.5 kg / 76 lb).

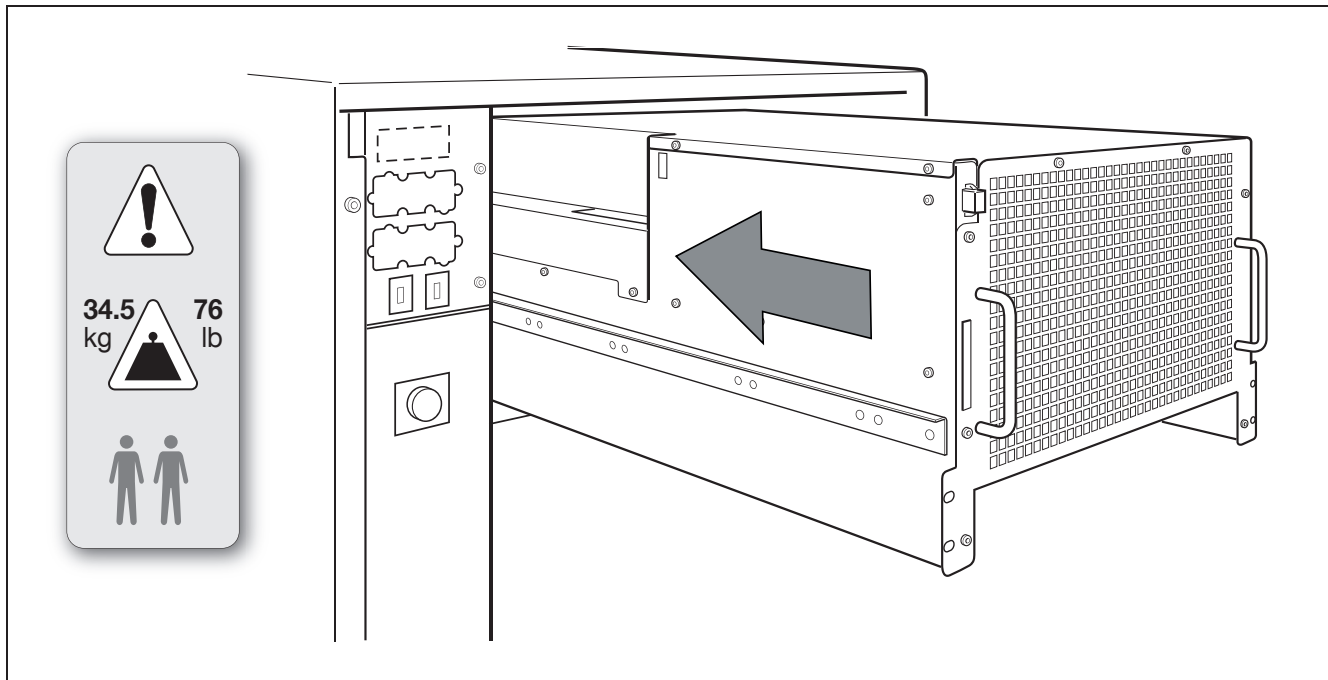

- Insert the connectors and secure them.

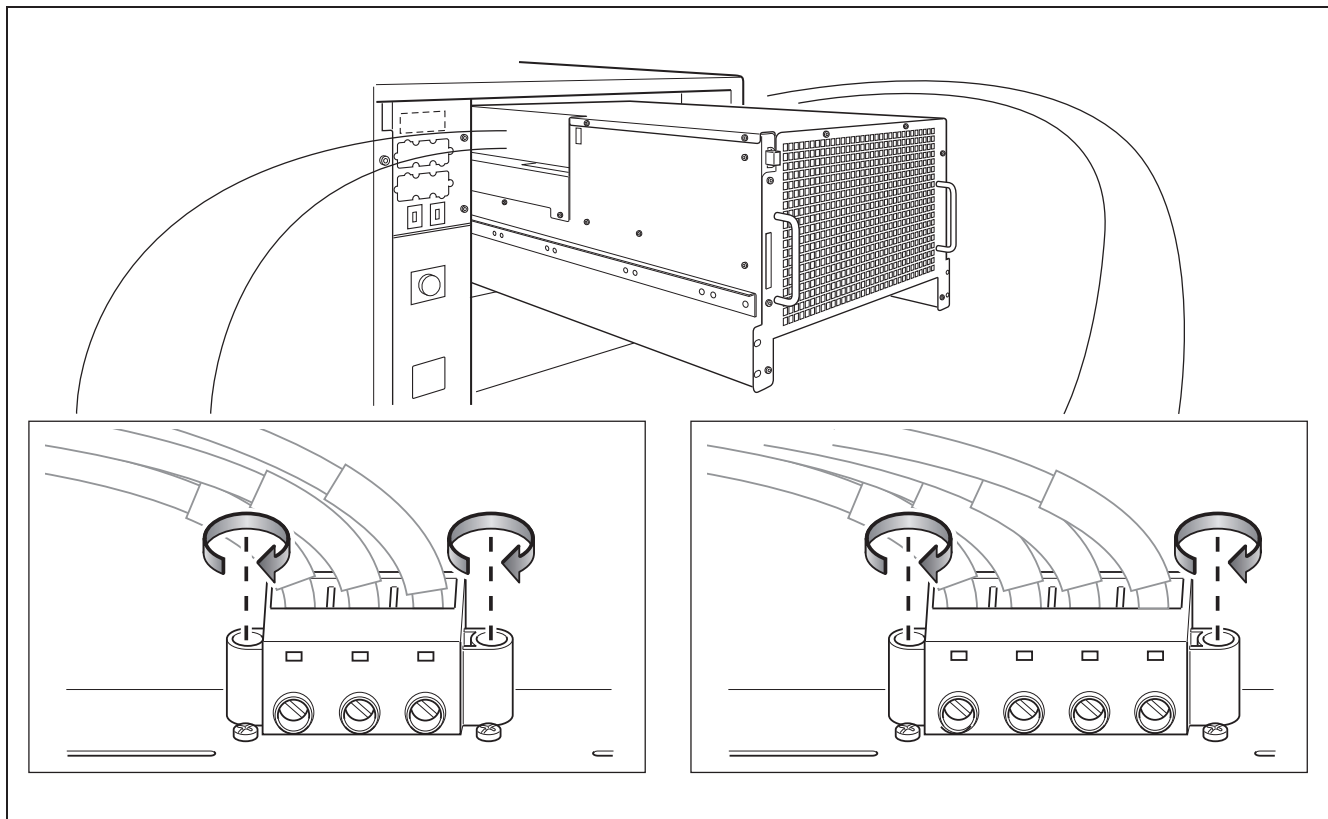

- Position the Lexan protection and secure it.

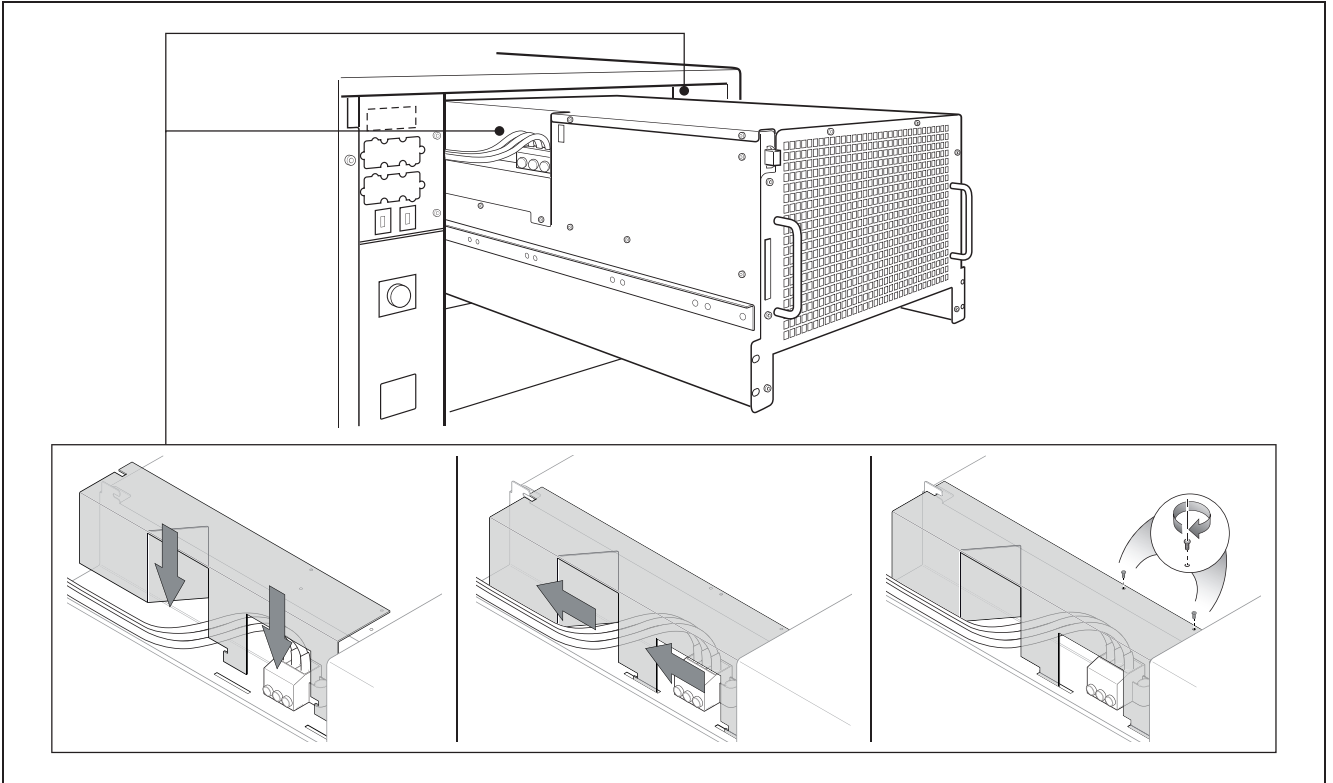

- Insert the module completely.
- Tighten the screws to secure the module to the SUNSYS PCS² IM.

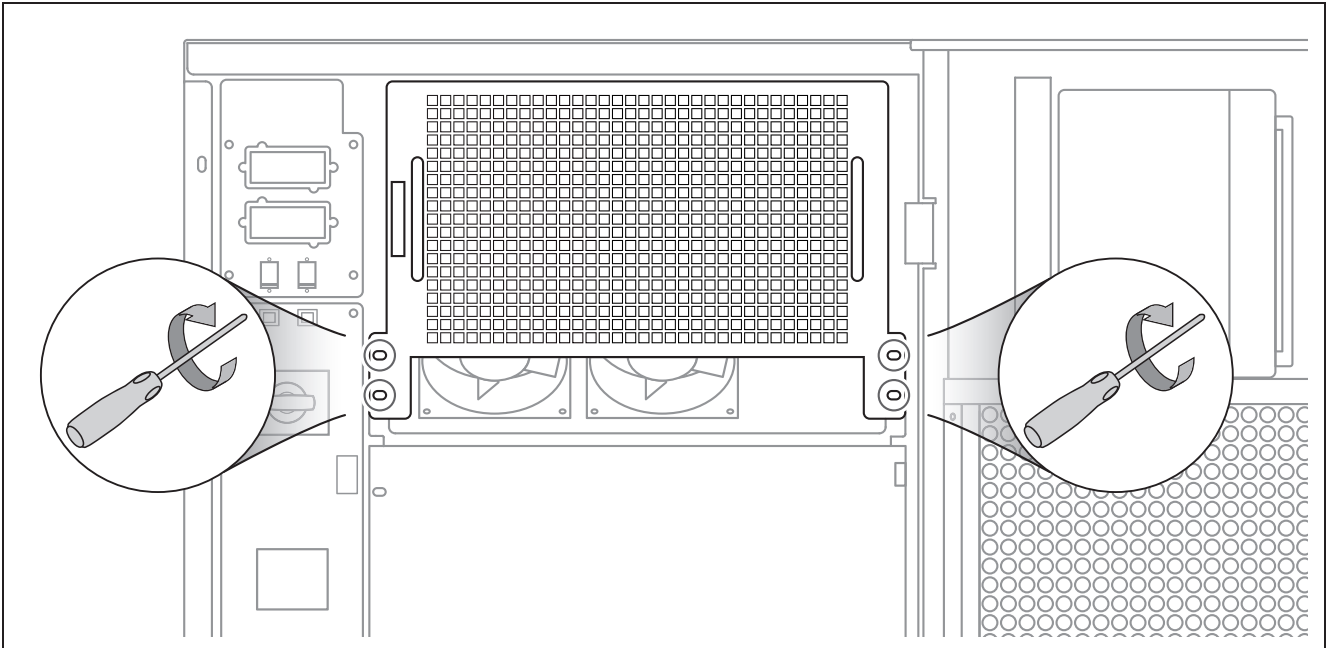

- Connect the communication cable.

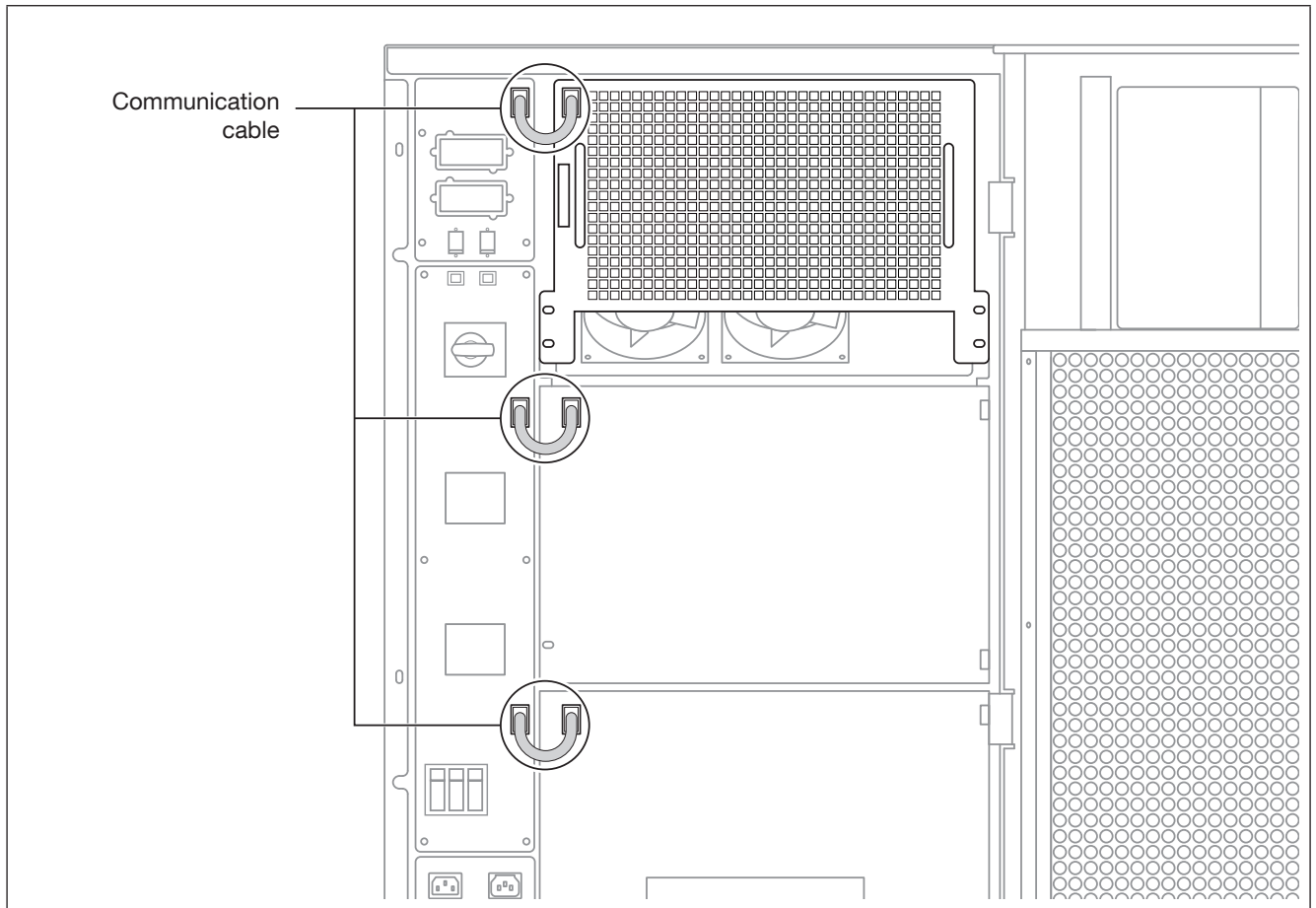

5.4.2 PROCEDURE FOR PCS² IM 132 - 200 TL

- Open the doors:
 - With the appropriate key A open the lock, then pull the hook B and open the right door.
 - Unhook the upper latch C and lower latch D and open the left door.

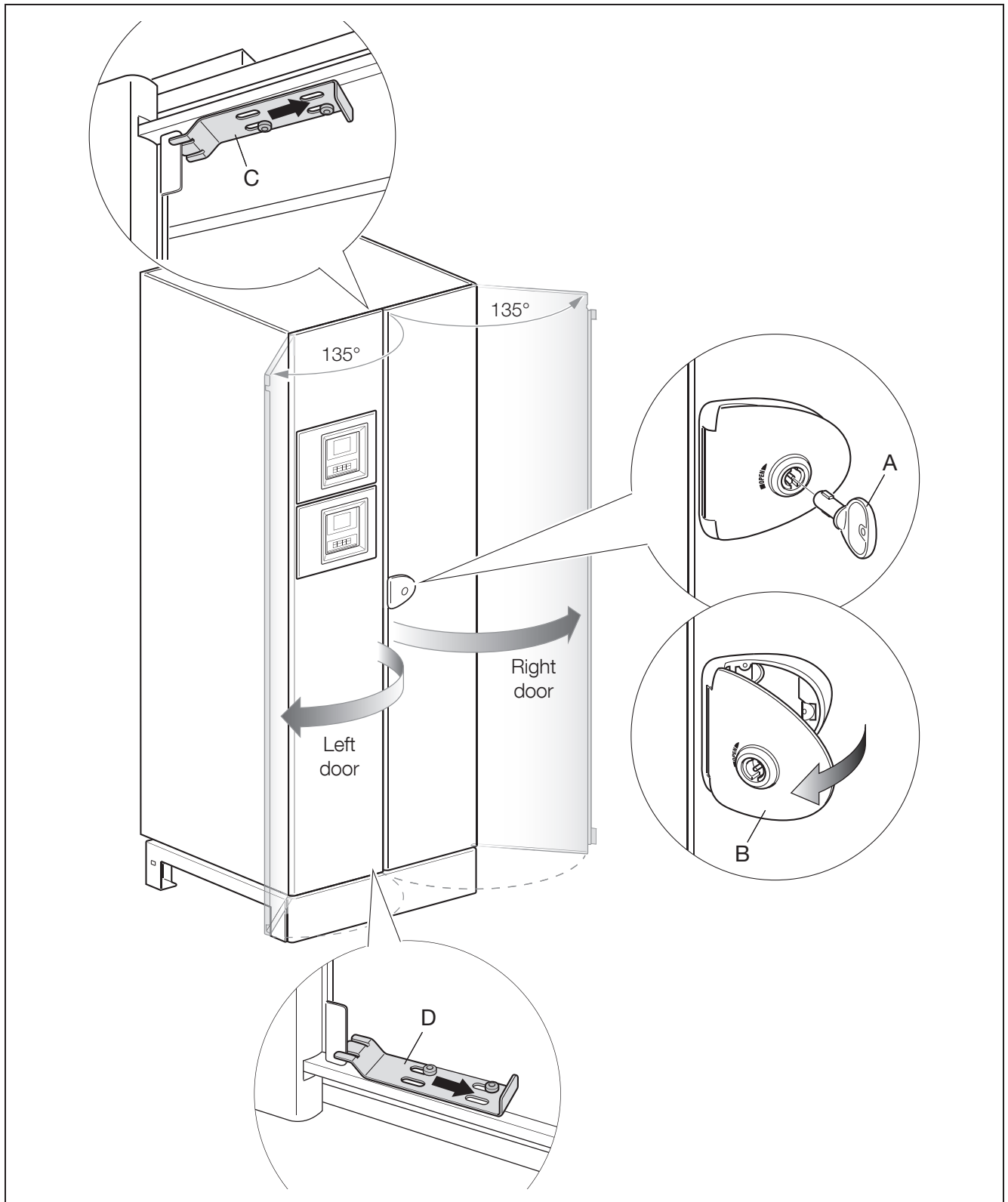

NOTE: in PCS2 132 TL, module A and D are not present.

- Position the cables in the hose clamp to enable correct module insertion.

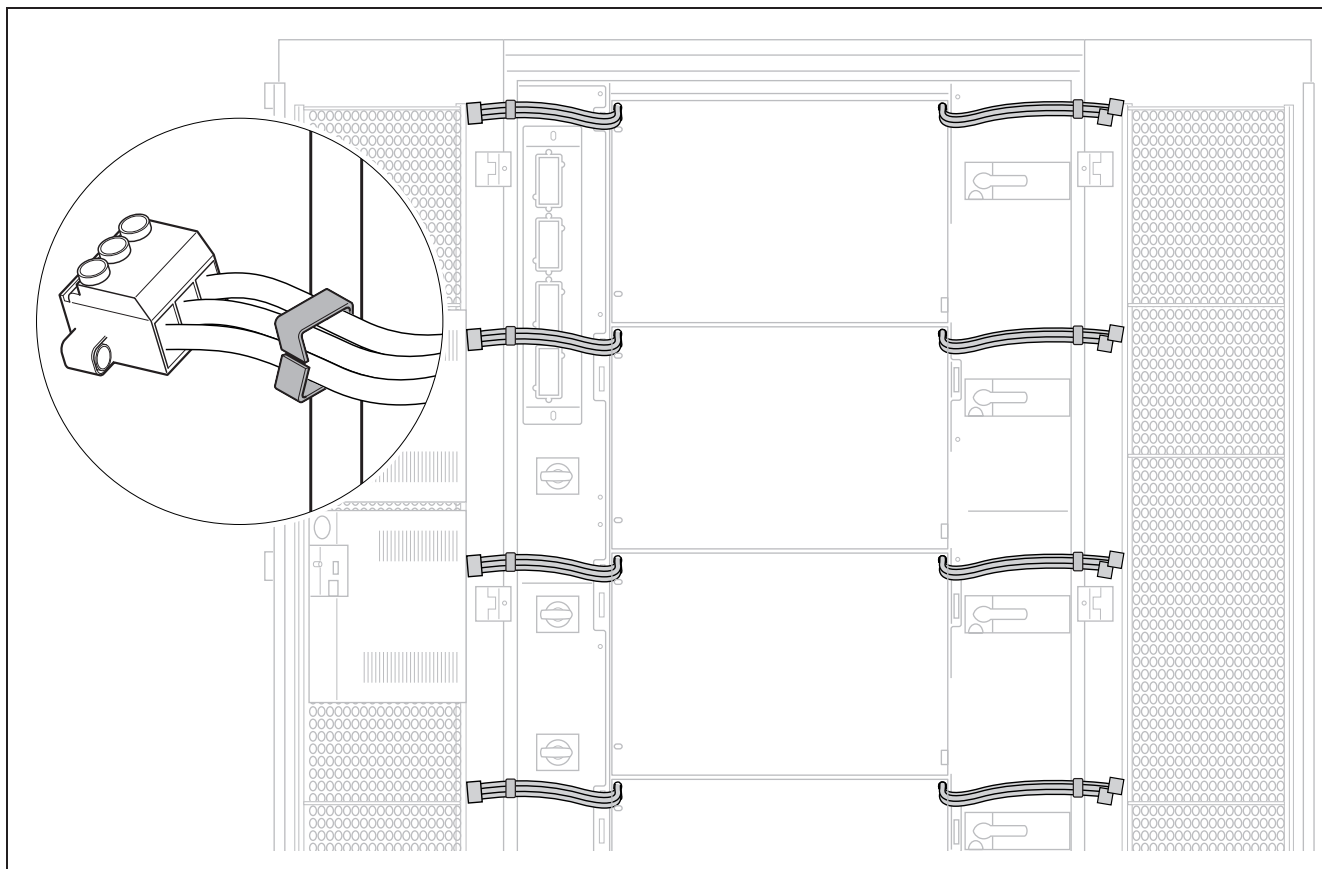

- Remove the Lexan protection on the connectors.

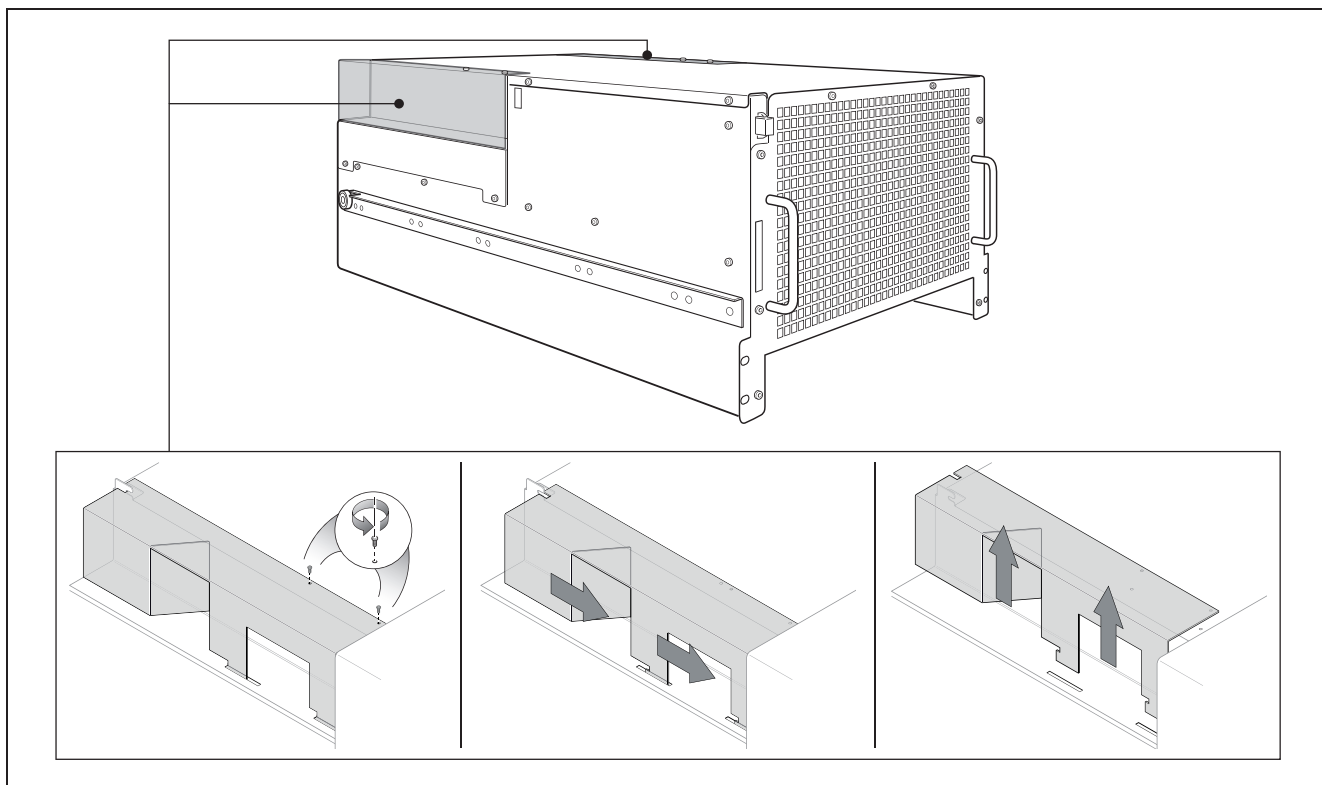

- Insertion of the lower three modules. Place the module on the guides and insert it up to the limit starting by the lower one.

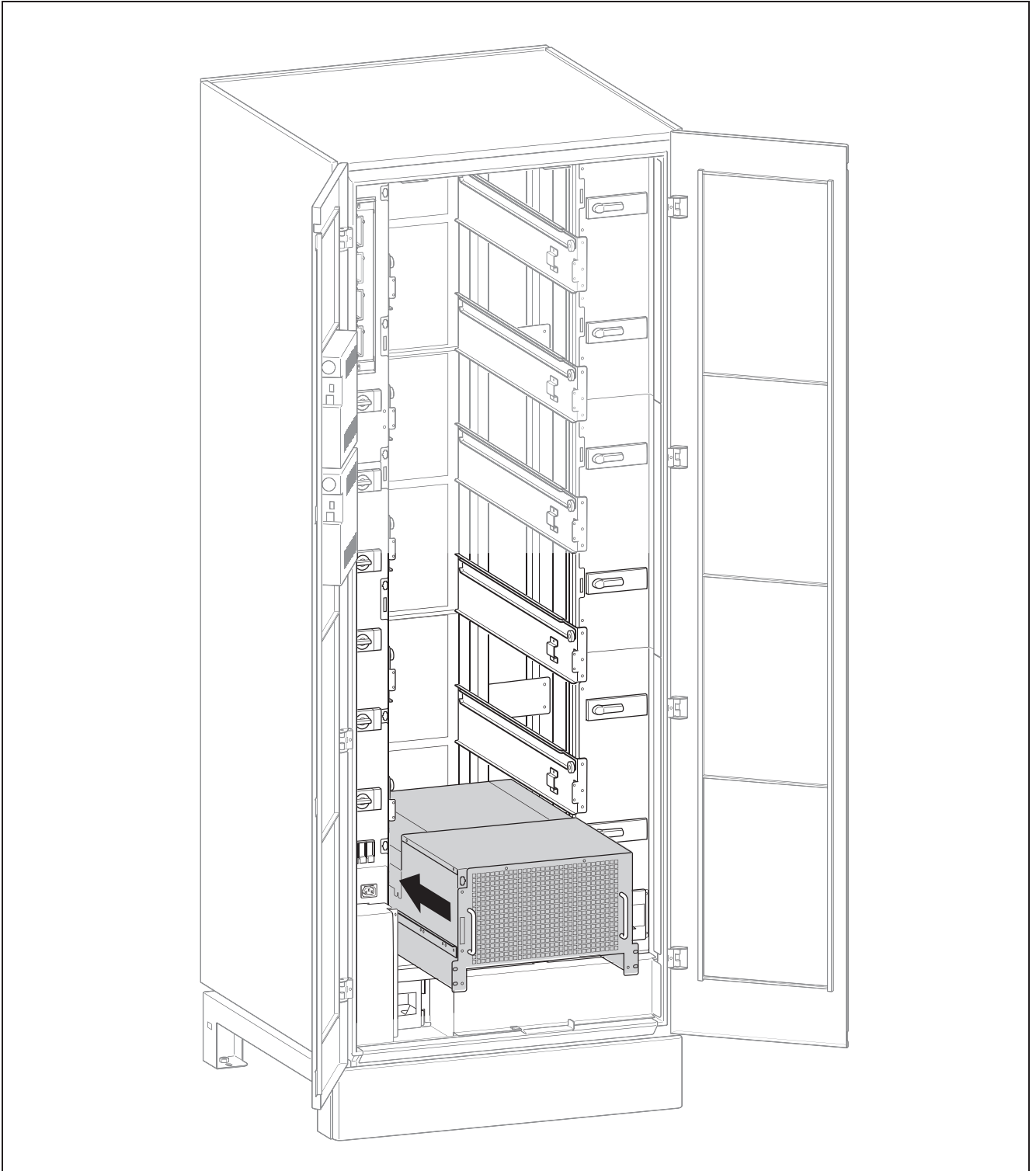

- Insertion of the upper three modules starting by the lower one.
 The Socomec shelf can be used to facilitate the insertion of the upper three modules.
 The shelf can be used only by persons authorized by Socomec.
 Keep this shelf available to service people for commissioning or future maintenance activities.
 - Disconnect the CAN-BUS cables.

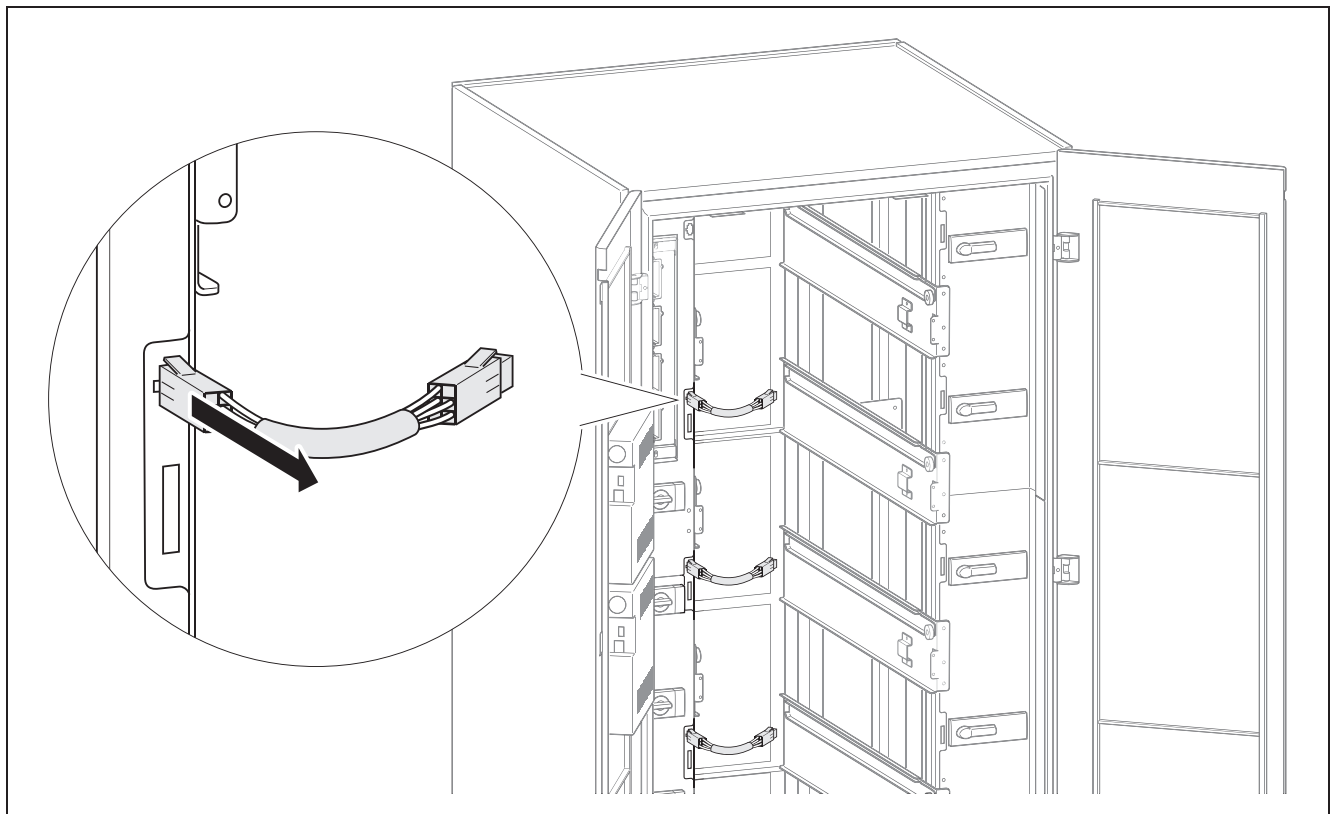

- Assemble the shelf on the PCS² IM frame inserting its joints into the PCS² IM frame holes.

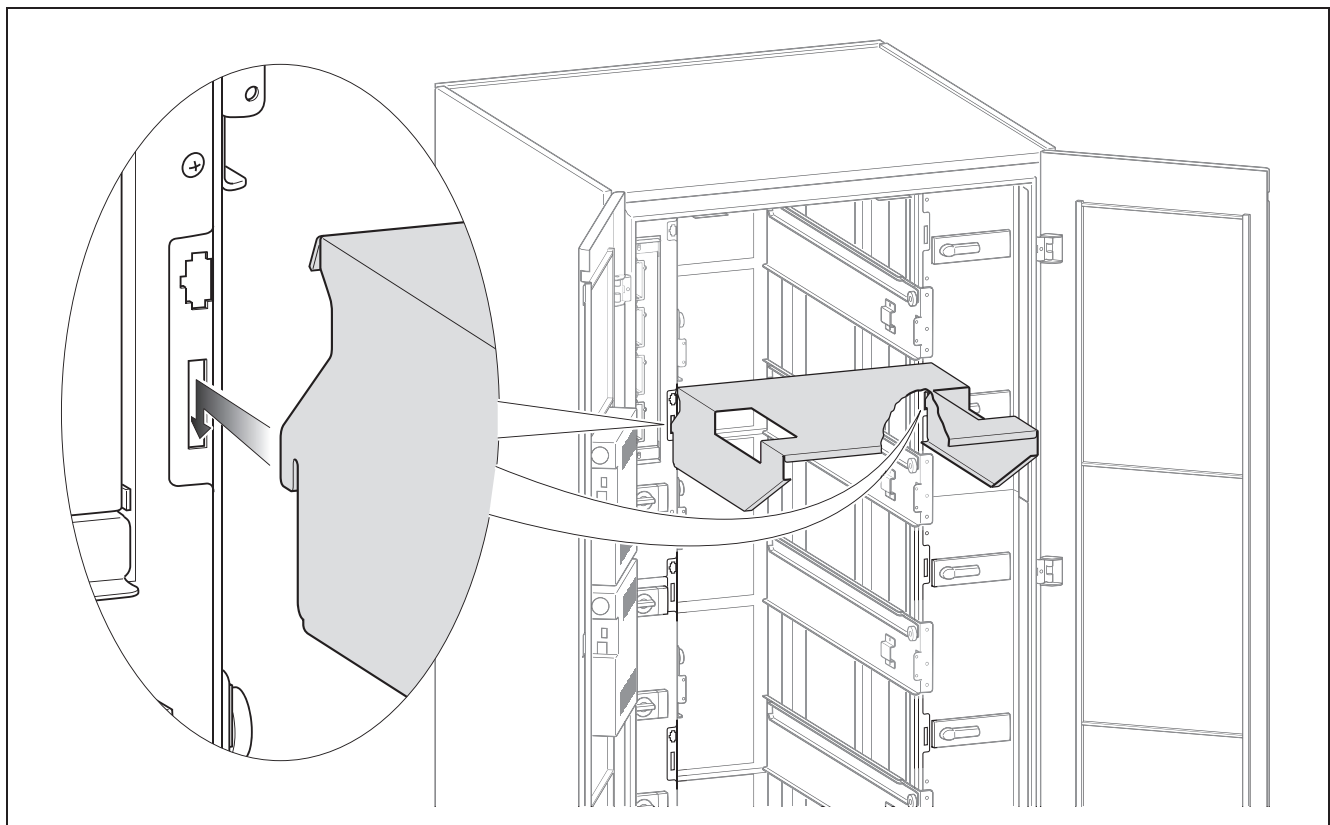

- Make sure the shelf is properly assembled.

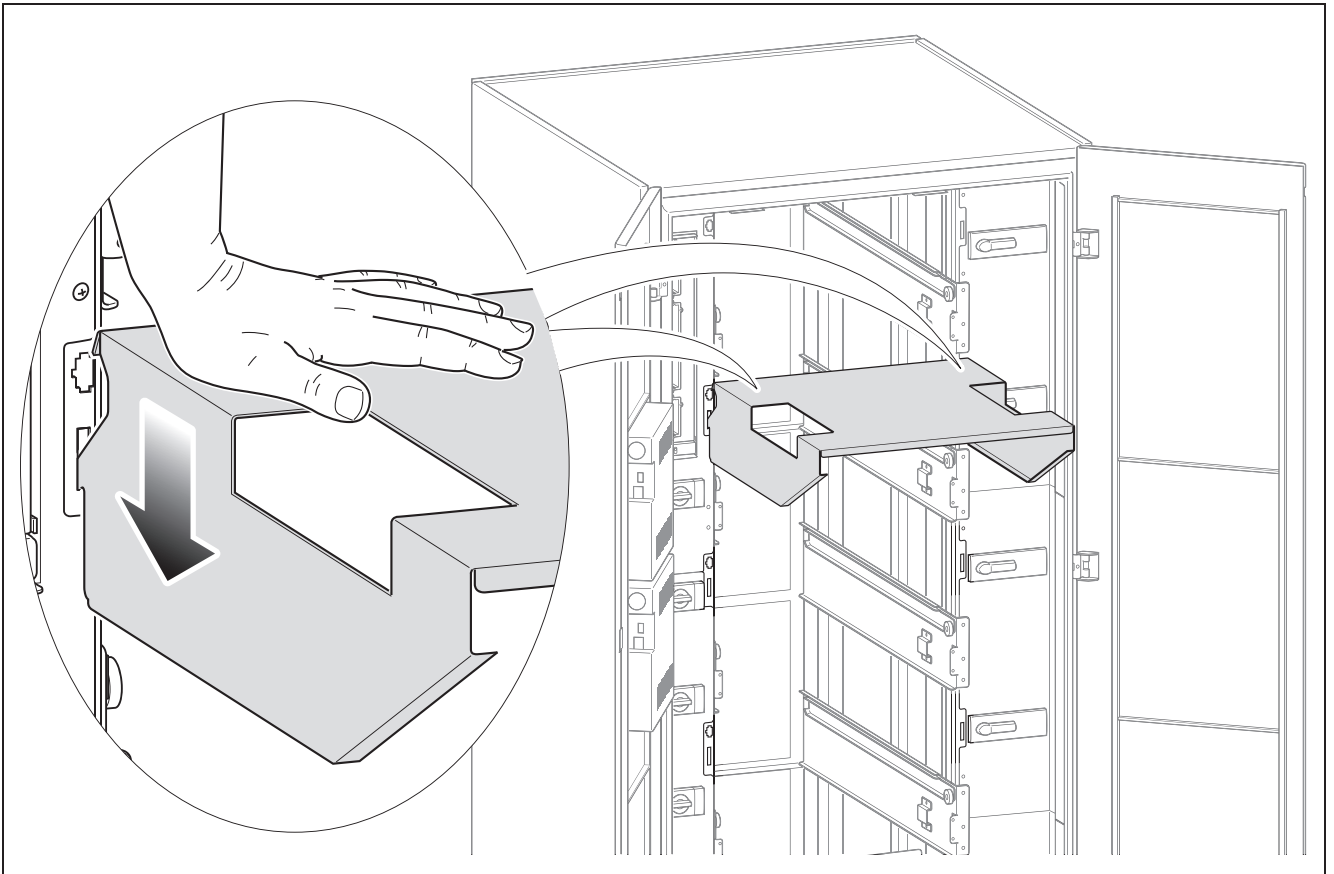

- Place the module on the shelf.

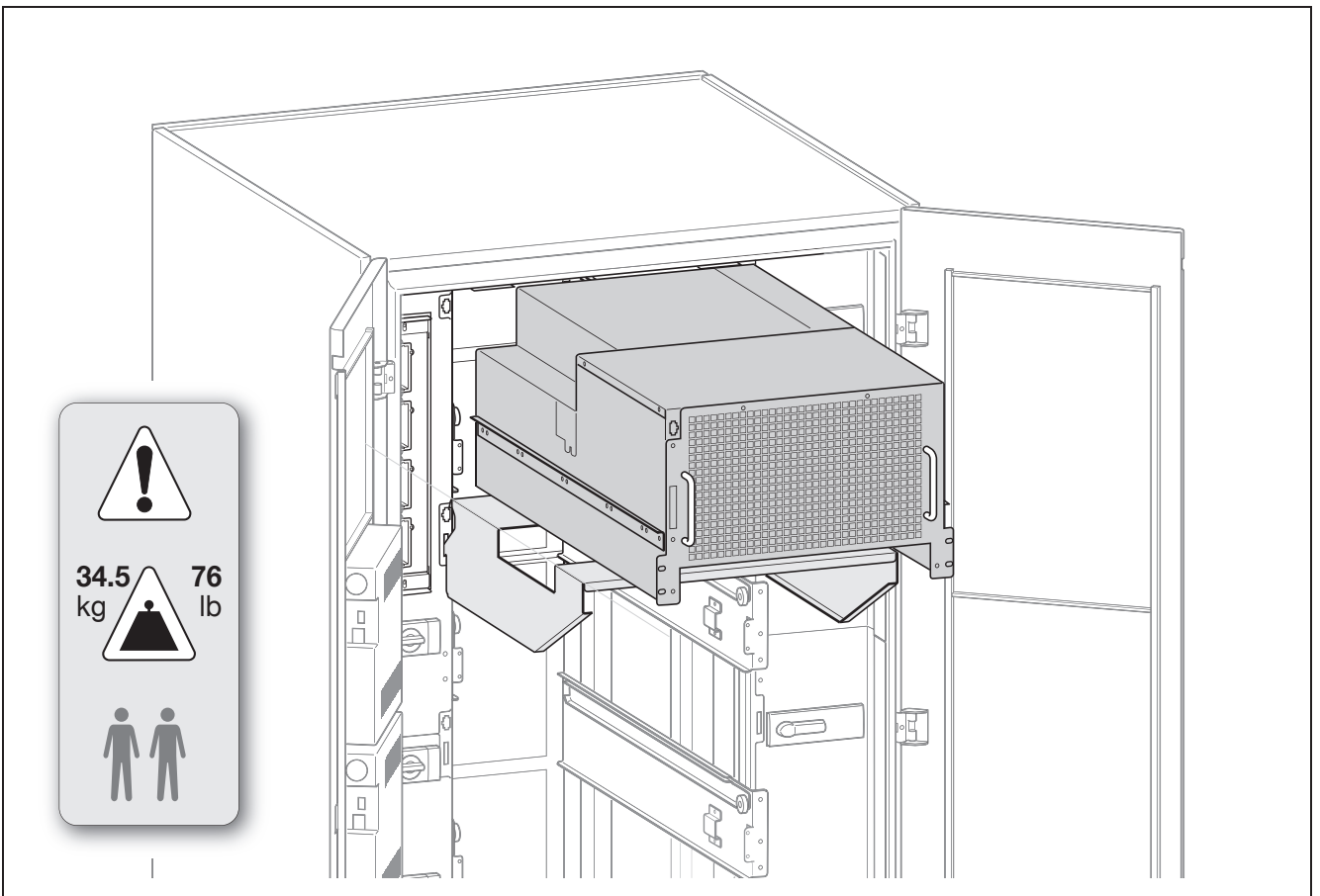

- Place the module on the guides and insert it up to the limit.

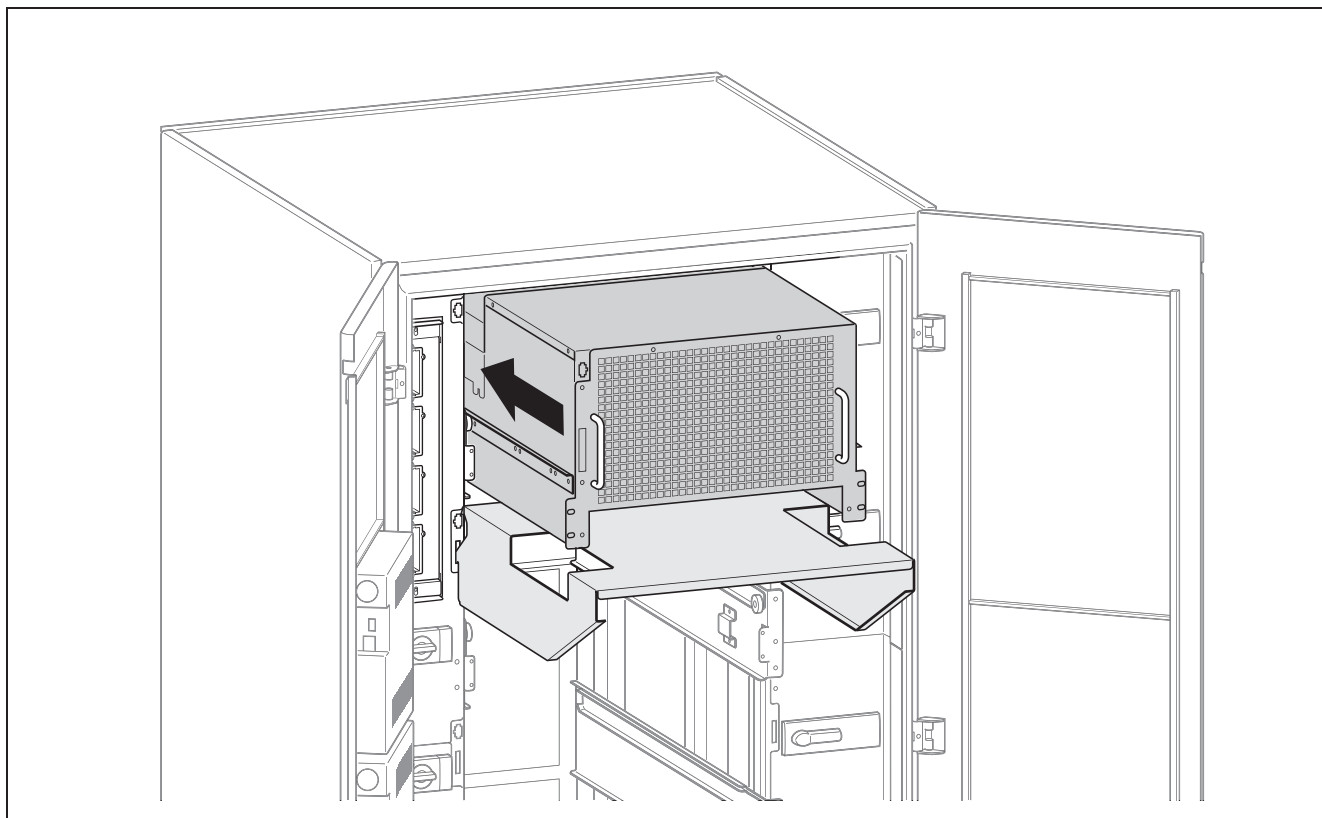

- Insert the connectors and secure them.

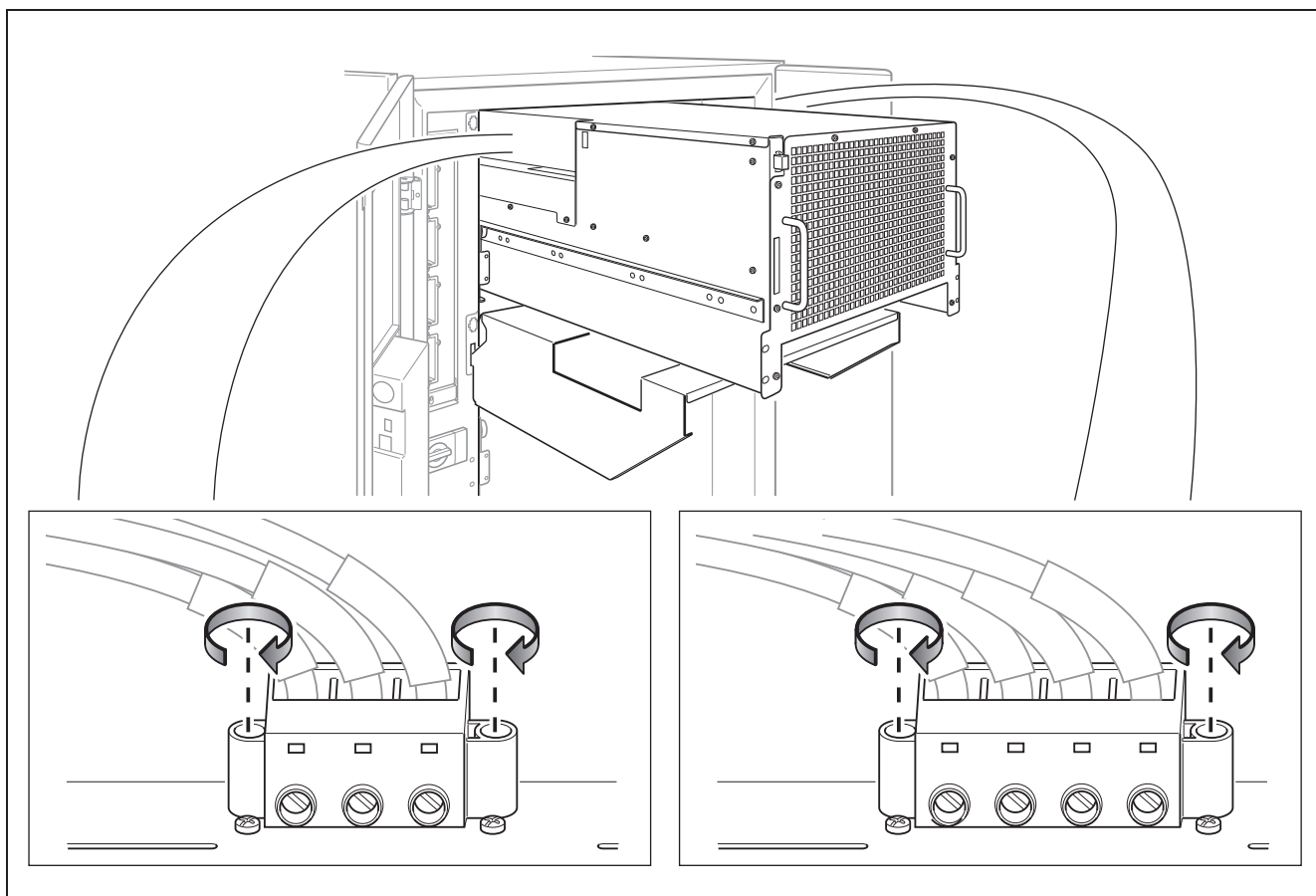

- Position the Lexan protection and secure it.

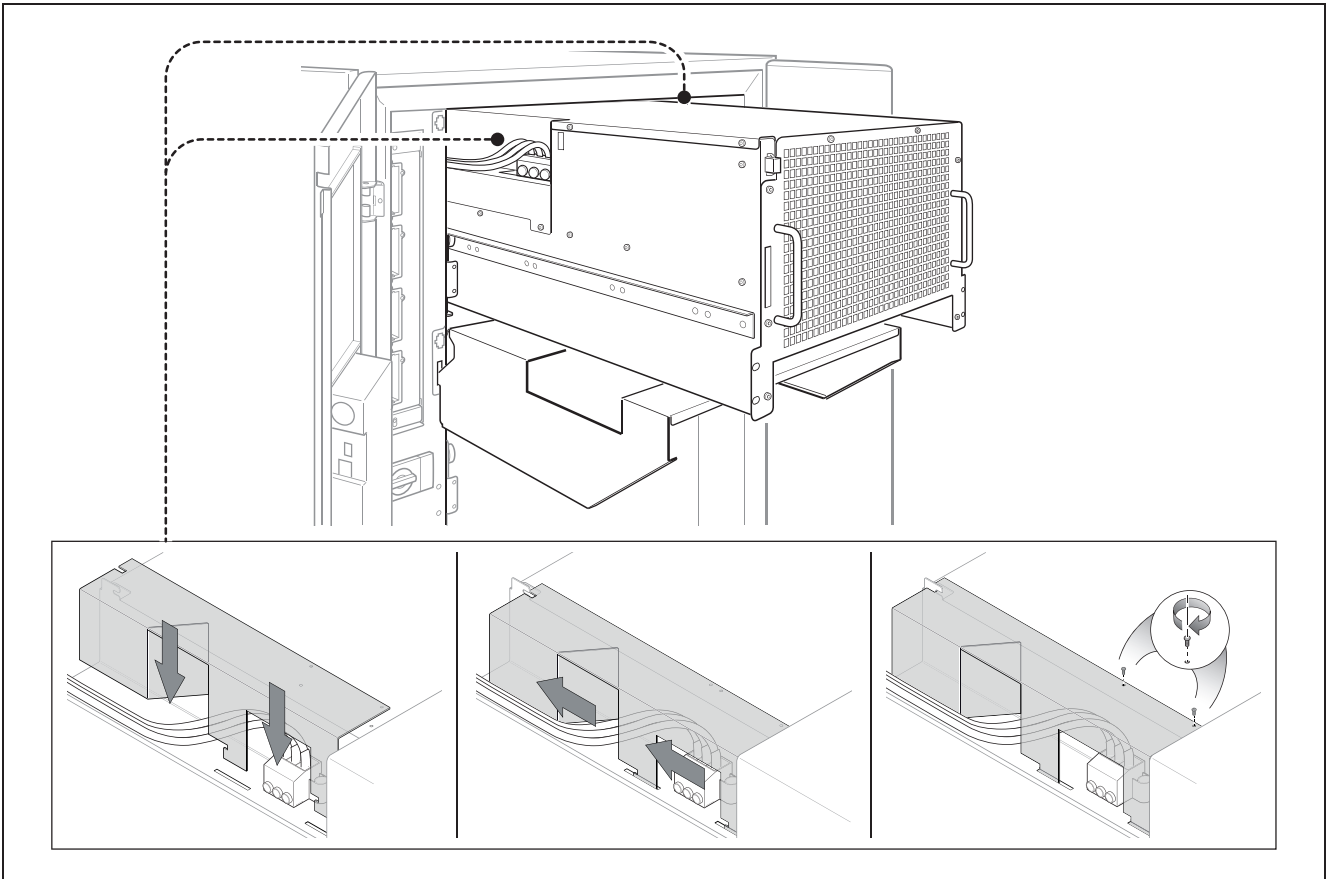

- Insert the module completely.
- Remove the shelf.

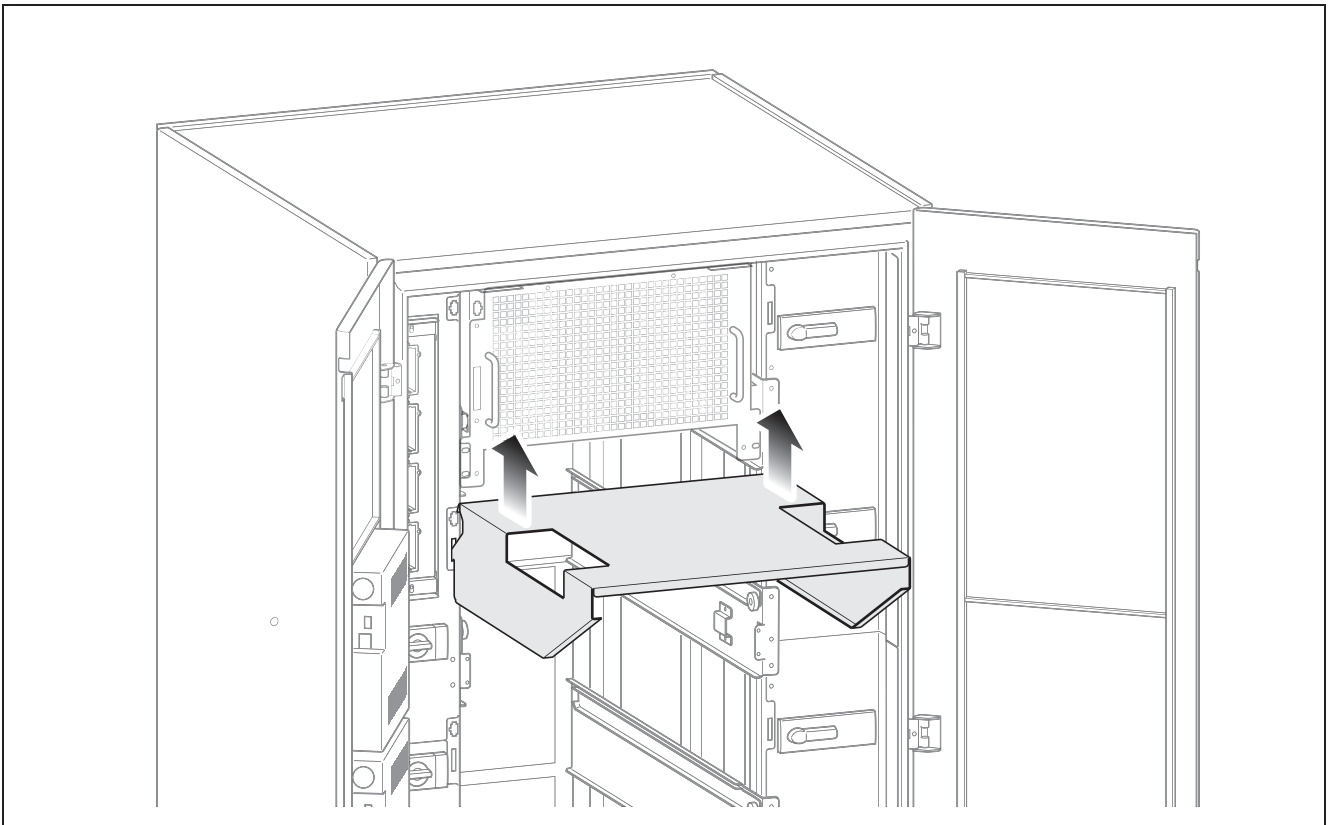

- Tighten the screws to secure the module to the SUNSYS PCS² IM.

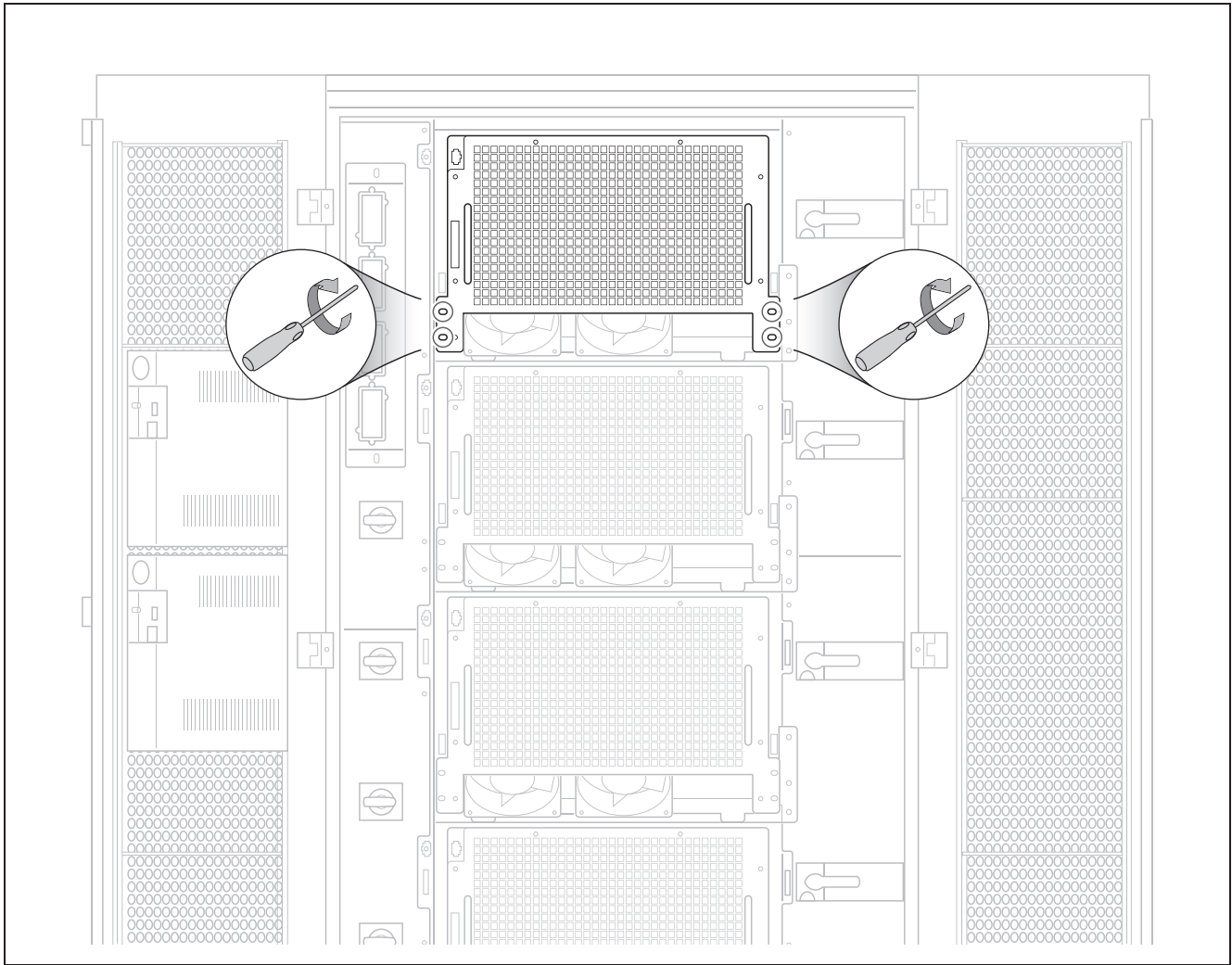

In PCS2 132 TL, the unused slots are covered with a panel, do not remove this protection.

- Connect the communication cable.

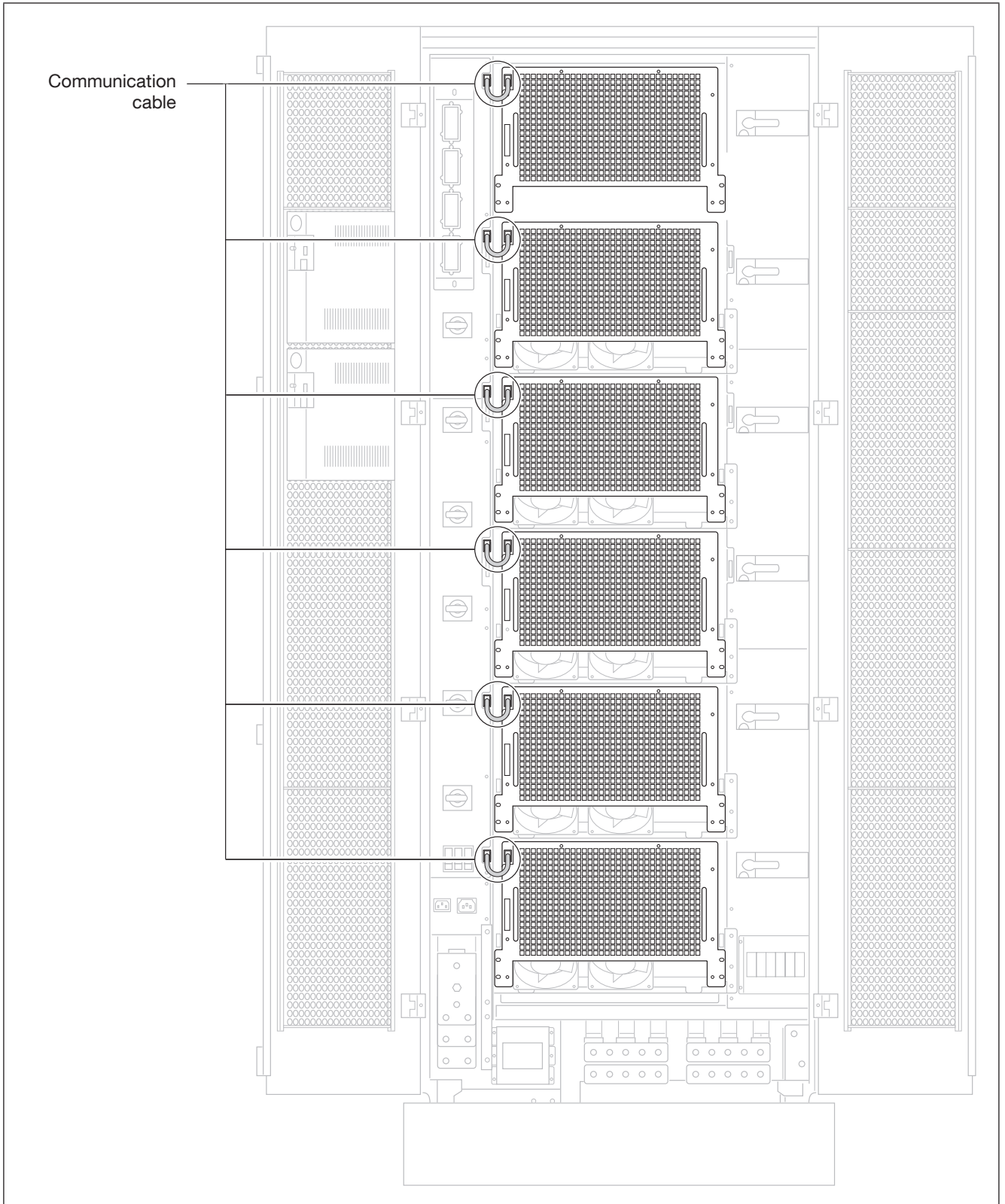

- Close the doors:
 - Close the left door and hook it with the both upper latch C and lower latch D.
 - Close the right leaf and close the hook B until the first clack. The door is locked but the lock is not activated.
 - To lock the door, press the coupling B fully.

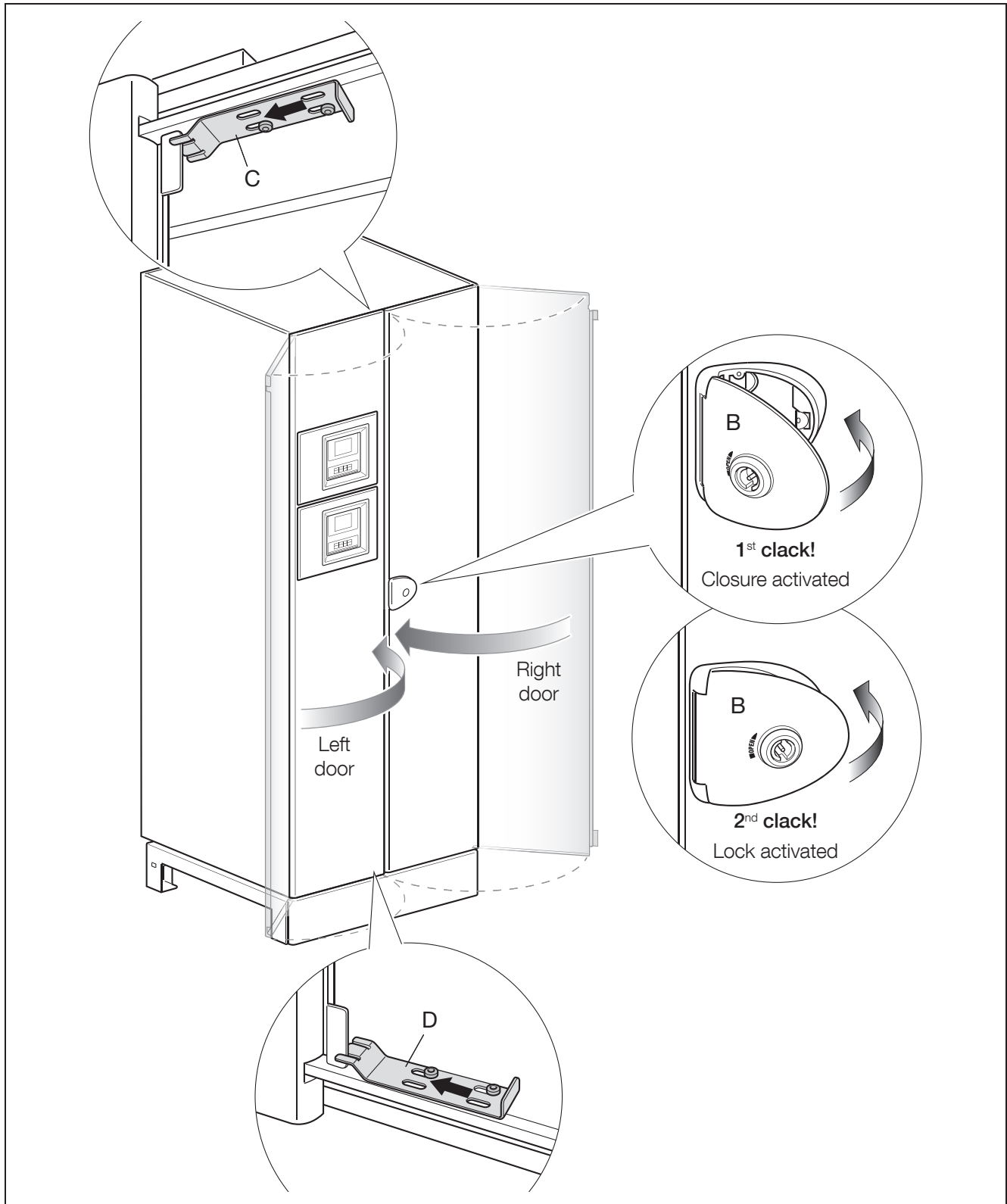

6. ELECTRICAL INSTALLATION



NOTE!

Before carrying out any operations on the unit read the 'Safety standards' chapter carefully.

6.1 ELECTRICAL REQUIREMENTS

The installation and system must comply with national plant regulations.

The electrical distribution panel must have a sectioning and protection system installed for AC mains.

The tables below show the connection features and the size of the protection devices recommended for correct installation.

Size of AC input protection					
Models	Required overcurrent protection	Recommended Insulation fault device	AC cable Max cross-section	Type of cable	Tightening torque
33 TR	63 A type D	Differential switch (RCD) ¹ 0.3 A Type AC or A	1 x 150 mm ² 3 x 120 mm ²	90 °C copper wire	20 Nm
66 TR	125 A type D				
100 TR	200 A type D				
132 TL	315 A type C	Insulation Monitoring Device (IMD)			
200 TL	500A type C				

1. It is advisable to carry out a preliminary check on the earth current leakage with the PCS installed and operational with the definitive configuration (batteries, etc.), so as to prevent the RCD tripping.

The auxiliary power supply socket must be protected with a 10 A magneto-thermal switch, curve C, and from category II overvoltages or greater.

DC input protection can be achieved either with a distributed or centralised fuse configuration (see example below).

Size of DC input protection				
Models	DC cable Max cross-section ¹	Type of cable	Distributed fuses	Centralised fuses ²
33 TR	2 x 120 mm ²	90 °C Copper wire	80 A – 1000 V Ultrafast	80 A -1000 V Ultrafast
66 TR				160 A -1000 V Ultrafast
100 TR				250 A -1000 V Ultrafast
132 TL				2 x 160 A -1000 V Ultrafast
200 TL				2 x 250 A -1000 V Ultrafast

1. Determined by the size of the terminals.

2. Standard configuration delivered with the product.

Distributed Fuses (example 100 kW)

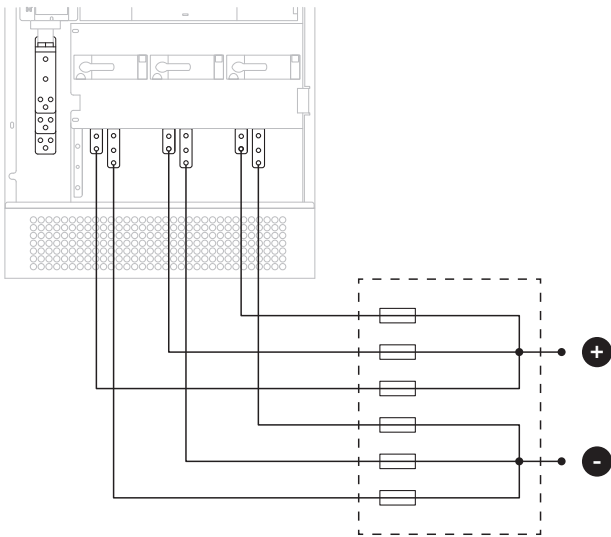

Centralised Fuses (example 100 kW)

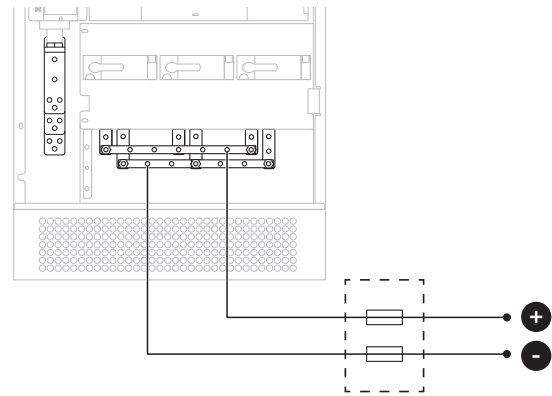

Distributed Fuses 132 - 200 kW - Centralised fuses is not allowed

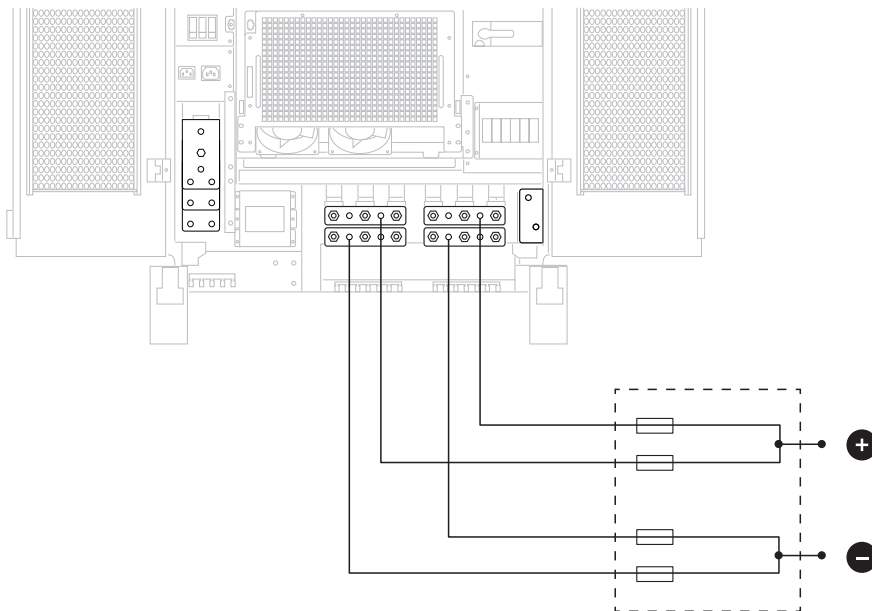

NOTE: If Socomec also provides the batteries the centralised fuse connection will be used and the fuses will be provided.



WARNING: the SUNSYS PCS² IM is designed for transient over-voltages in category II installations for AC terminals. If the SUNSYS PCS² IM can be subjected to transient over-voltages in category III installations, protective SPDs must be provided for the AC power supply network. The SPD AC option, designed to protect against category III overvoltages, can be fitted directly to the SUNSYS PCS² IM.
If this is used the distance between the SUNSYS PCS² IM and type I centralised SPD protection must be ≥ 15 m.



WARNING: the SUNSYS PCS² IM is designed for transient over-voltages in category II installations for DC terminals. If the SUNSYS PCS² IM can be subjected to transient over-voltages in category III installations, or if the distance from the SPDs of the battery cabinet is excessive, protective SPDs must be fitted near the SUNSYS PCS² IM. The SPD DC option can be fitted to the SUNSYS PCS² IM directly.

7. OVERVIEW

7.1 SWITCHES AND INTERFACES

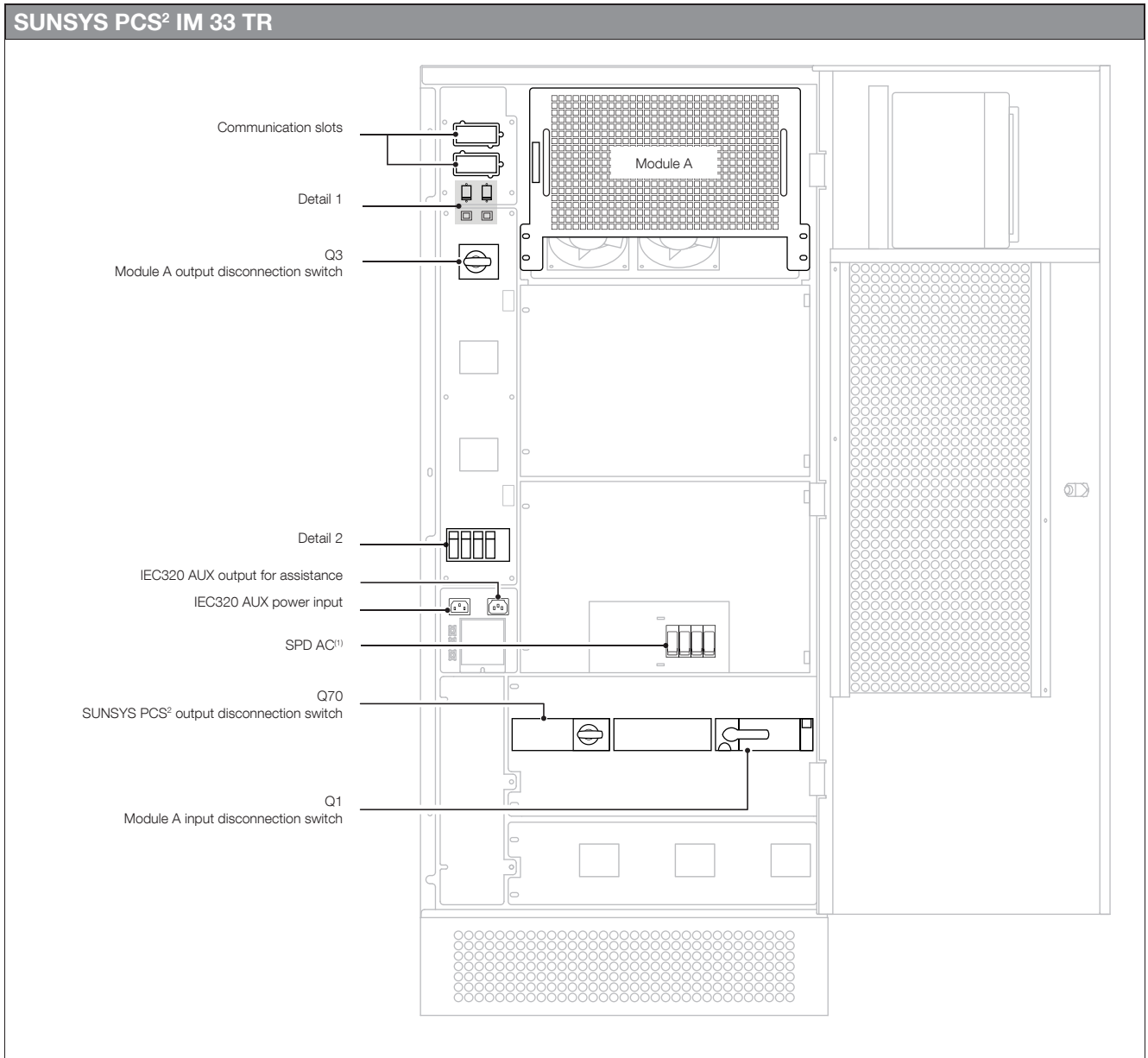

Detail 1	Detail 2: disconnection switches with fuse
<p>RS232/485 RS232</p> <p>Button TEST (option) Button RESET (option)</p>	<ol style="list-style-type: none"> 1. Disconnection switch for isolation controller (option). 2. Disconnection switch for isolation controller (option). 3. Disconnection switch for IEC320 connector AUX power supply. 4. Disconnection switch for IEC320 connector for assistance.

1. Refer to 'Standard features and options' chapter for details.

WIRING DIAGRAM FOR SUNSYS PCS² IM 33 TR

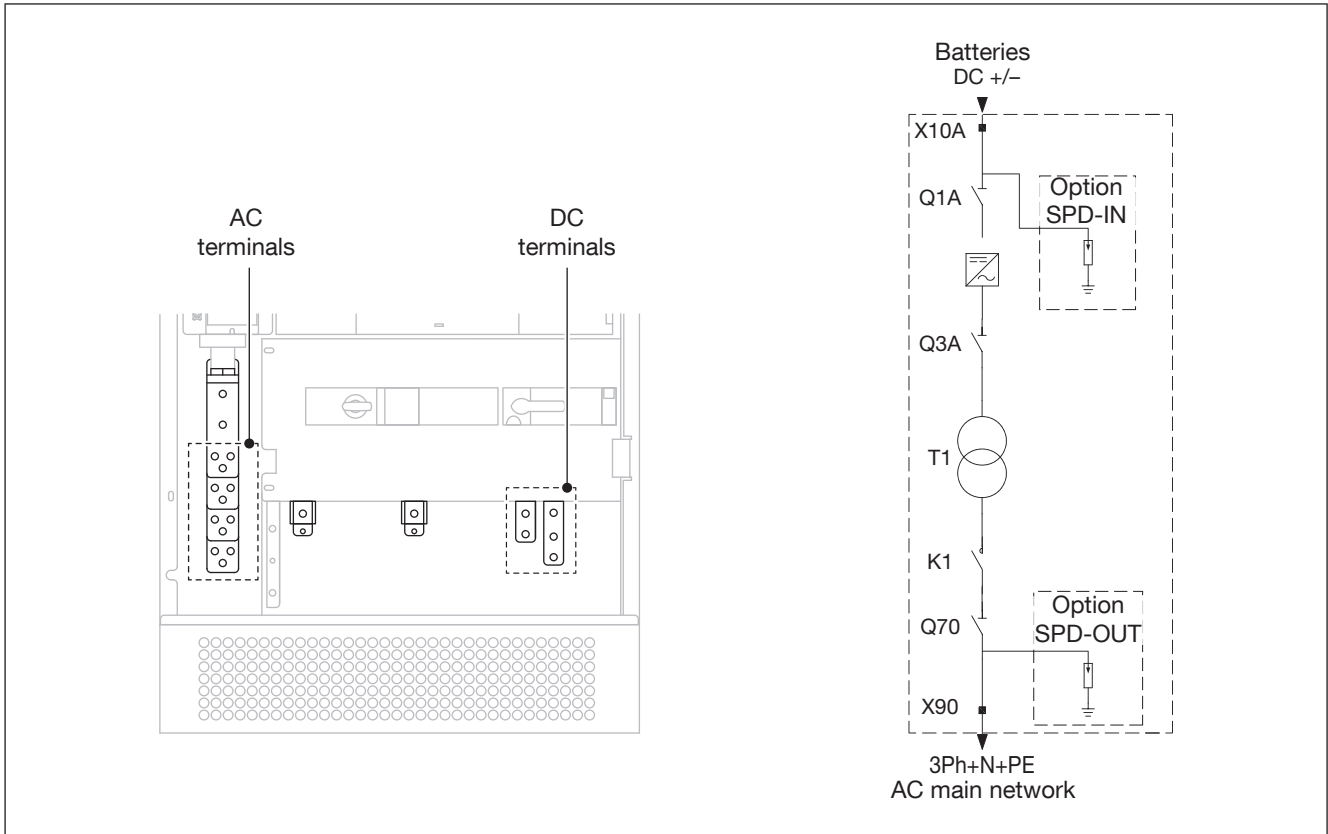

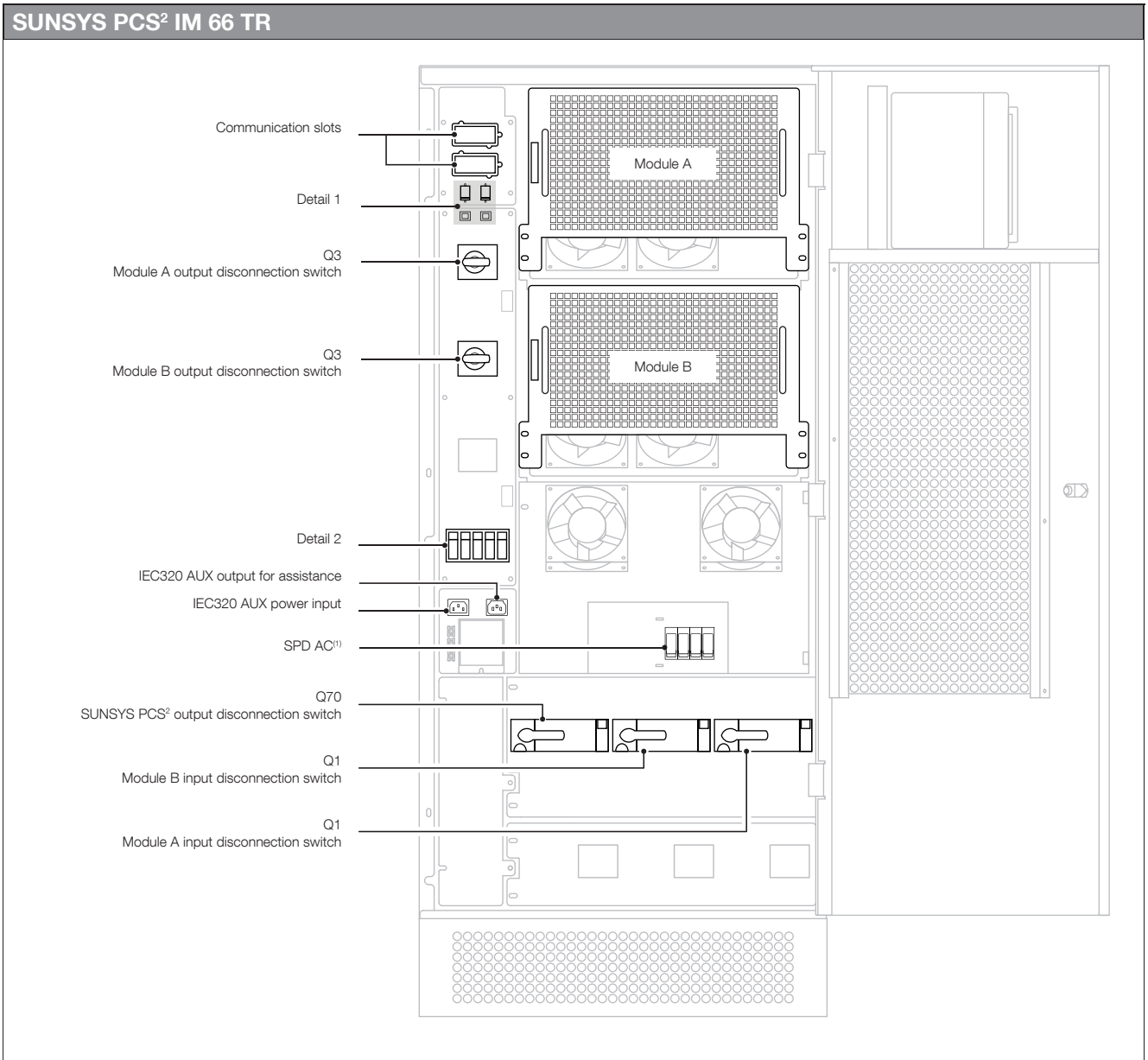

Detail 1	Detail 2: disconnection switches with fuse
<p>RS232/485 RS232</p> <p>Button TEST (option) Button RESET (option)</p>	<ol style="list-style-type: none"> 1. Disconnection switch for isolation controller (option). 2. Disconnection switch for isolation controller (option). 3. Disconnection switch for IEC320 connector AUX power supply. 4. Disconnection switch for IEC320 connector for assistance. 5. Fan fuse.

1. Refer to 'Standard features and options' chapter for details.

WIRING DIAGRAM FOR SUNSYS PCS² IM 66 TR

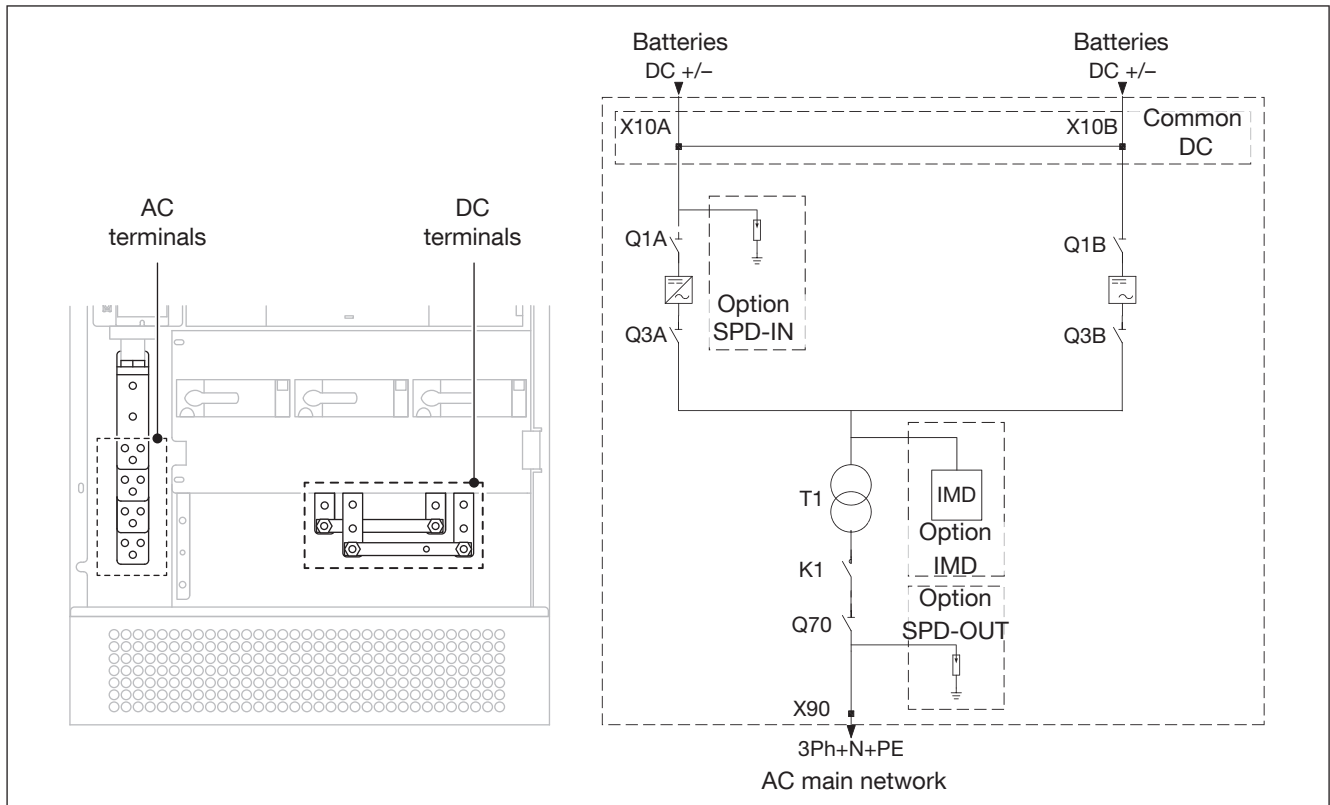

SUNSYS PCS² IM 100 TR

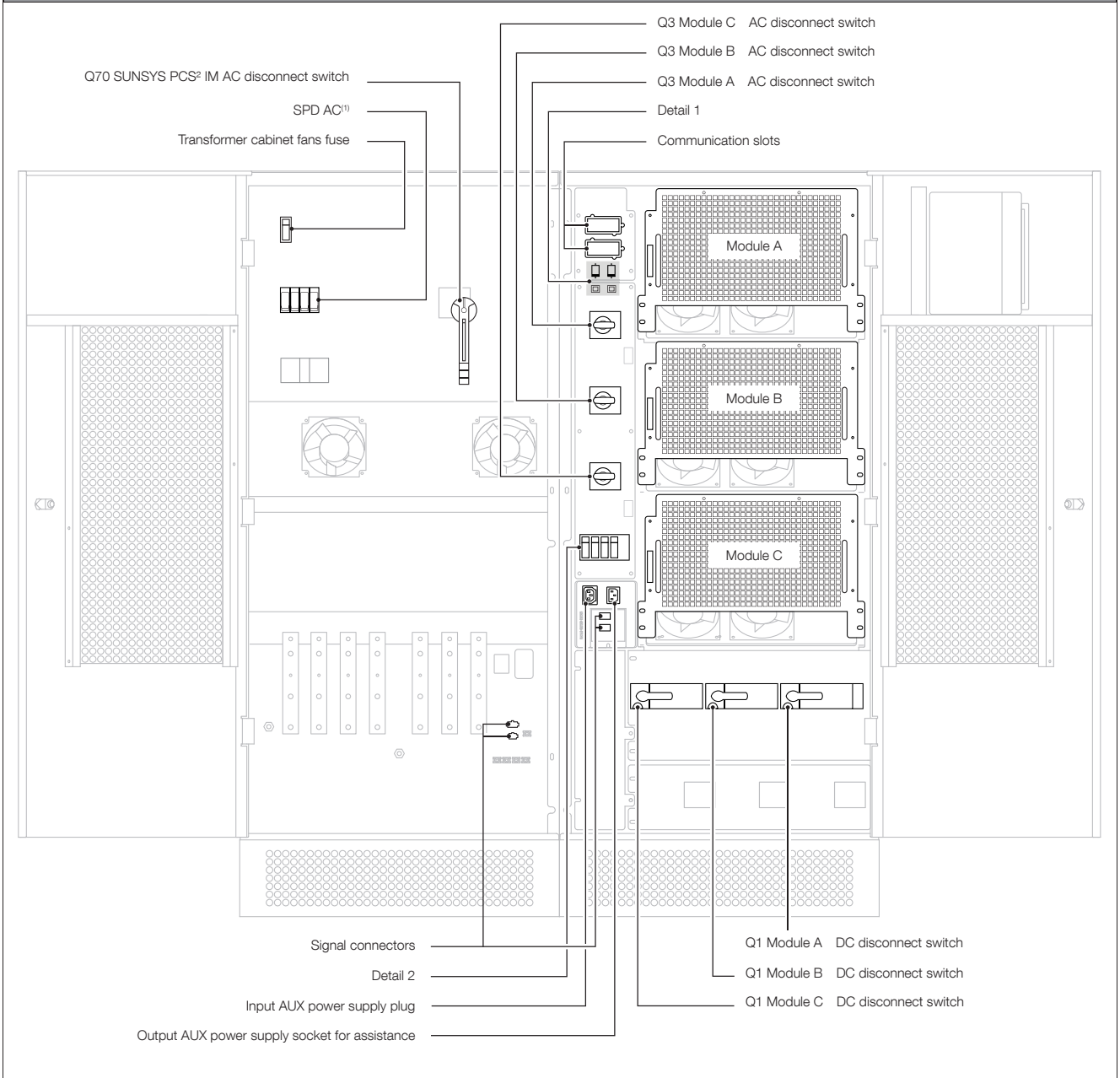

Detail 1	Detail 2: disconnection switches with fuse
<p>RS232/485 RS232</p> <p>Button TEST (option) Button RESET (option)</p>	<ol style="list-style-type: none"> 1. Disconnection switch for isolation controller (option). 2. Disconnection switch for isolation controller (option). 3. Disconnection switch for IEC320 connector AUX power supply. 4. Disconnection switch for IEC320 connector for assistance.

1. Refer to 'Standard features and options' chapter for details.

WIRING DIAGRAM FOR SUNSYS PCS² IM 100 TR

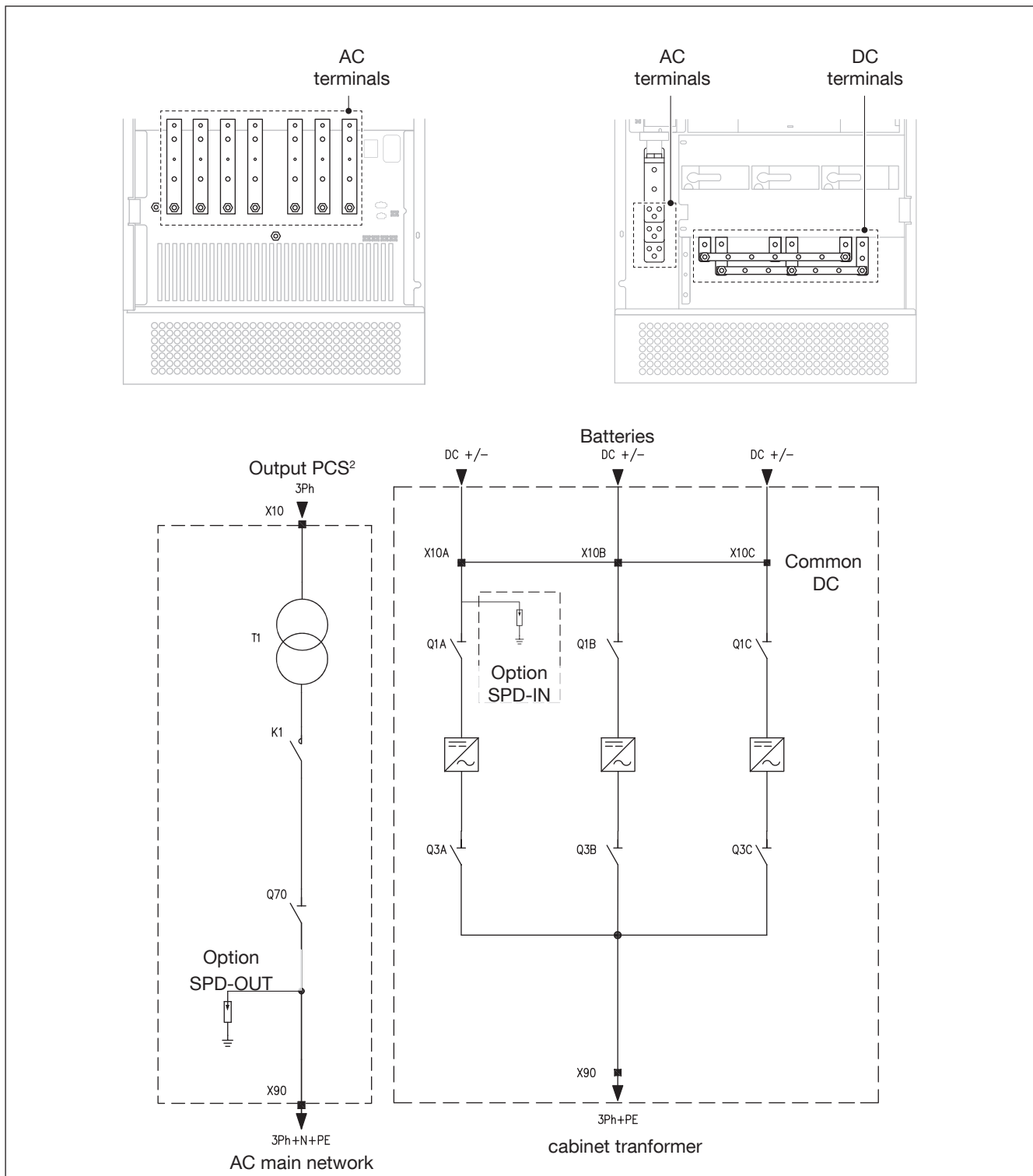

NOTE: for transformer based models (PCS2 IM 33-66-100TR), formal compliance to specific grid-code standards can require 3-wire output only (w/o neutral connection), while operating in grid-tied mode. Contact Socomec for further information.

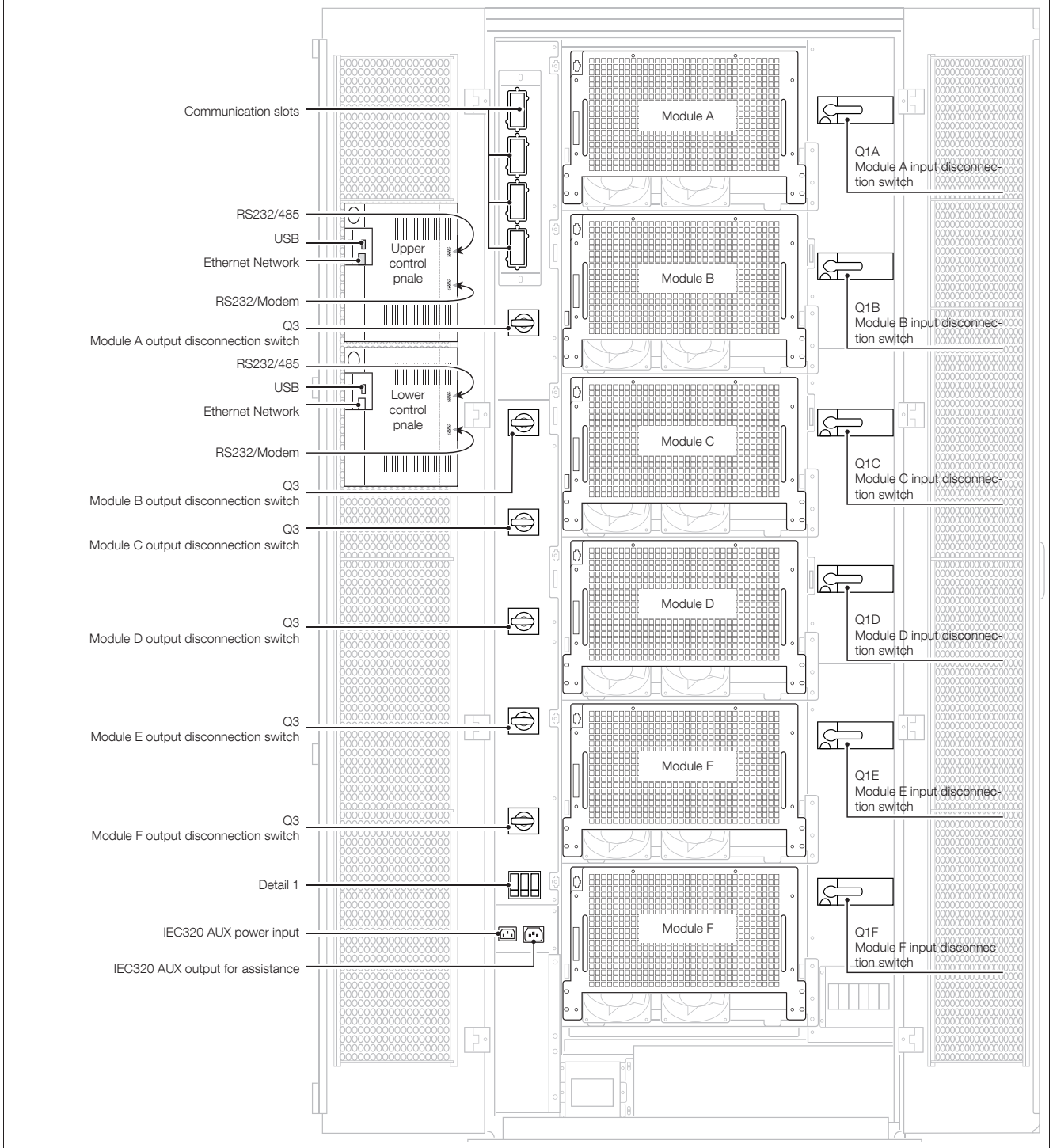

Detail 1: disconnection switches with fuse

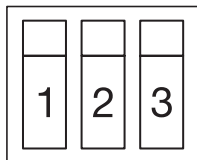

1. Disconnection switch for IEC320 connector AUX power supply (Upper Control Panel)
2. Disconnection switch for IEC320 connector AUX power supply (Lower Control Panel)
3. Disconnection switch for IEC320 connector for assistance

1. In PCS² 132 TL, module A & D are not present.

WIRING DIAGRAM OF SUNSYS PCS² IM 132 - 200 TL

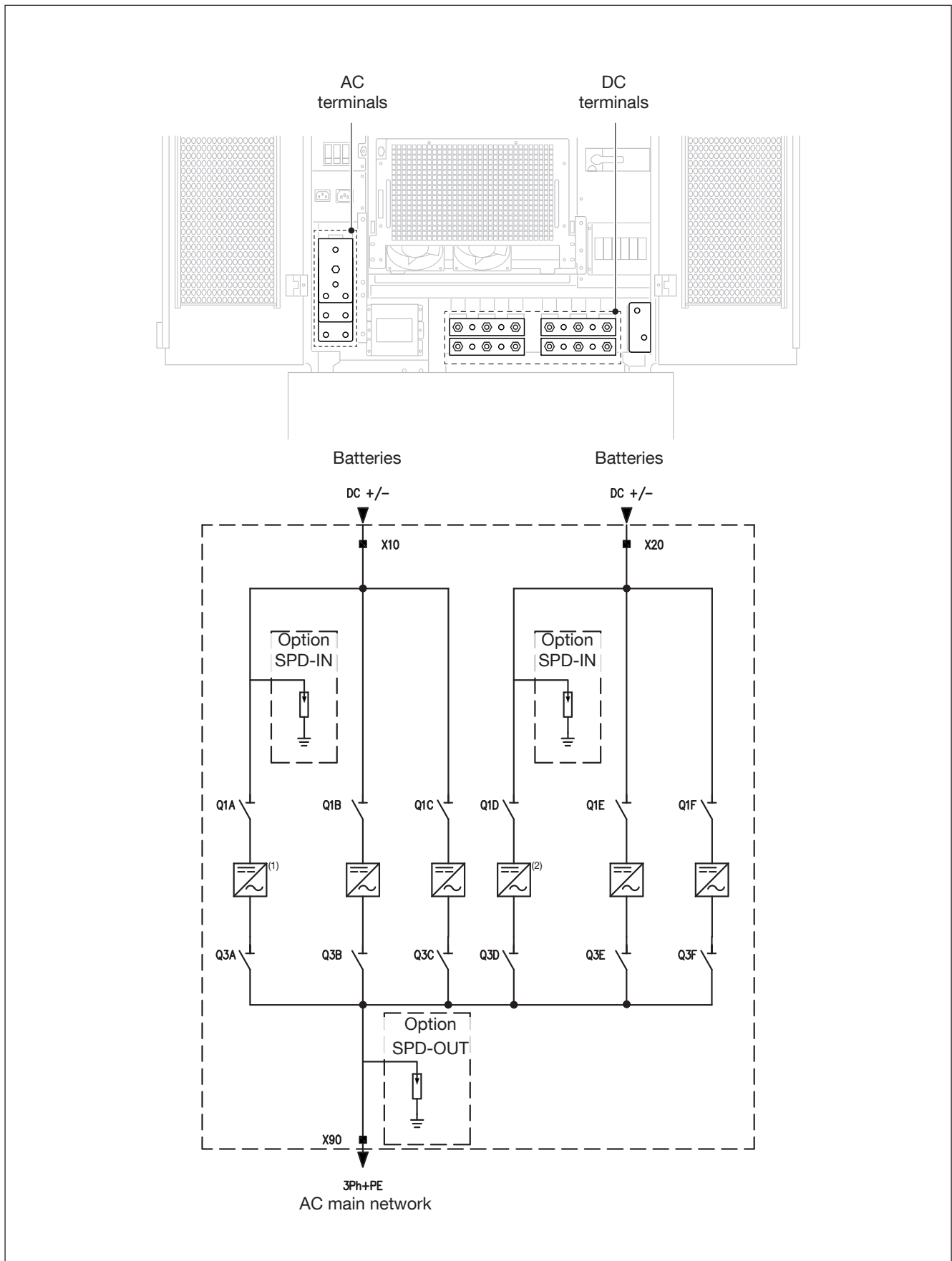

1. Module A not present in PCS 132 TL
2. Module D not present in PCS 132 TL

7.2 DIAGRAM OF MAIN SYSTEM EXAMPLE FOR VERSION 100 TR

The SUNSYS PCS² system is constructed using power electronics modules. Each power module incorporates circuit protection, sine filter, cooling fans and EMI filtering as shown in the diagram below.

- Example for PCS² 100kW with transformer

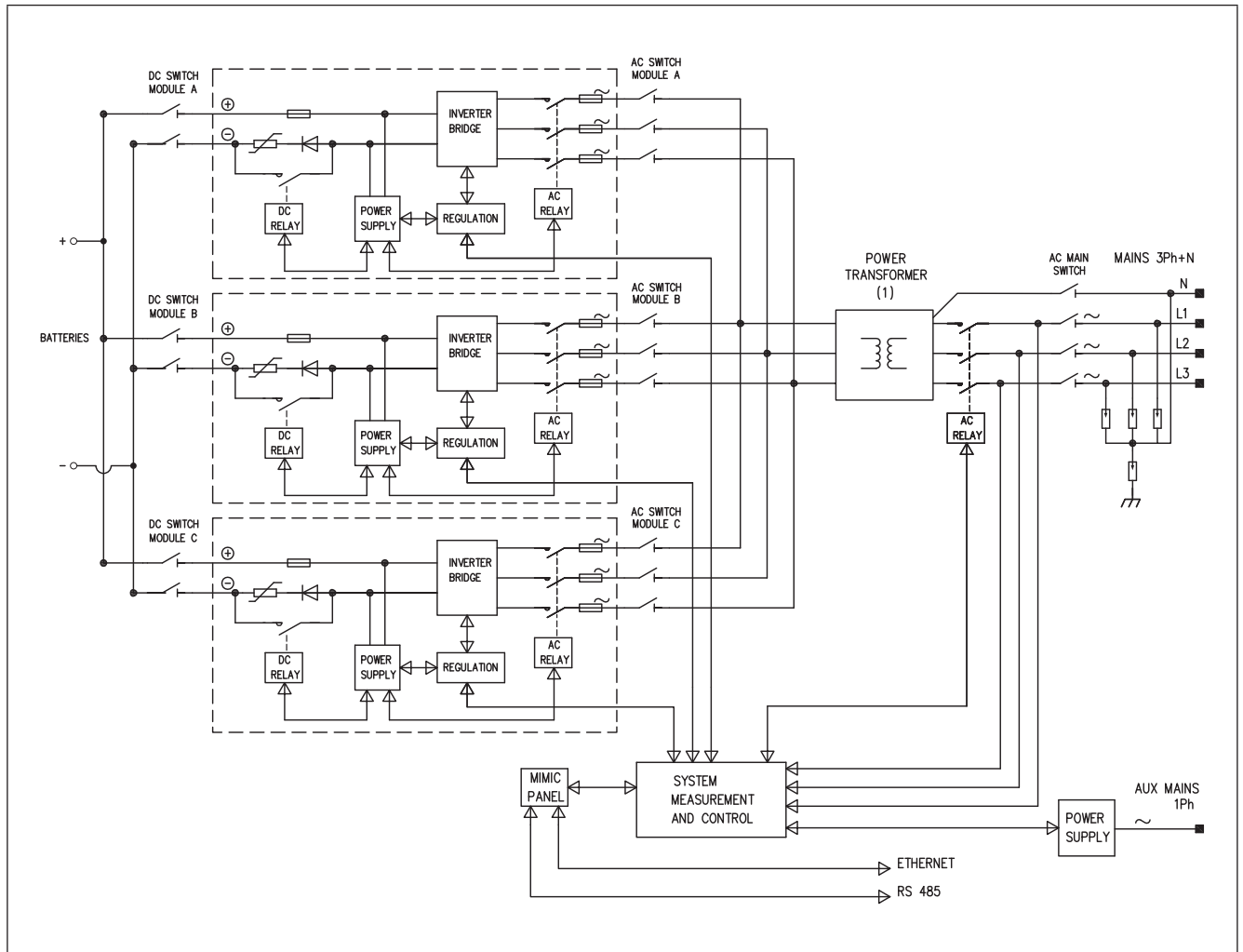

1. AC voltage is set according to the country electric code.

8. CONNECTIONS



NOTE!

Before carrying out any operations on the unit read the 'Safety standards' chapter carefully.

8.1 INPUT CONNECTION

The SUNSYS PCS² IM is connected to the batteries via the DC terminals.

The SUNSYS PCS² IM is connected to the AC mains via the AC power terminals.

- Remove the panels protecting the connection area in front of the terminals.
- Remove the horizontal support in order to facilitate the cable connections.

SUNSYS PCS² IM range 33-66-100 TR

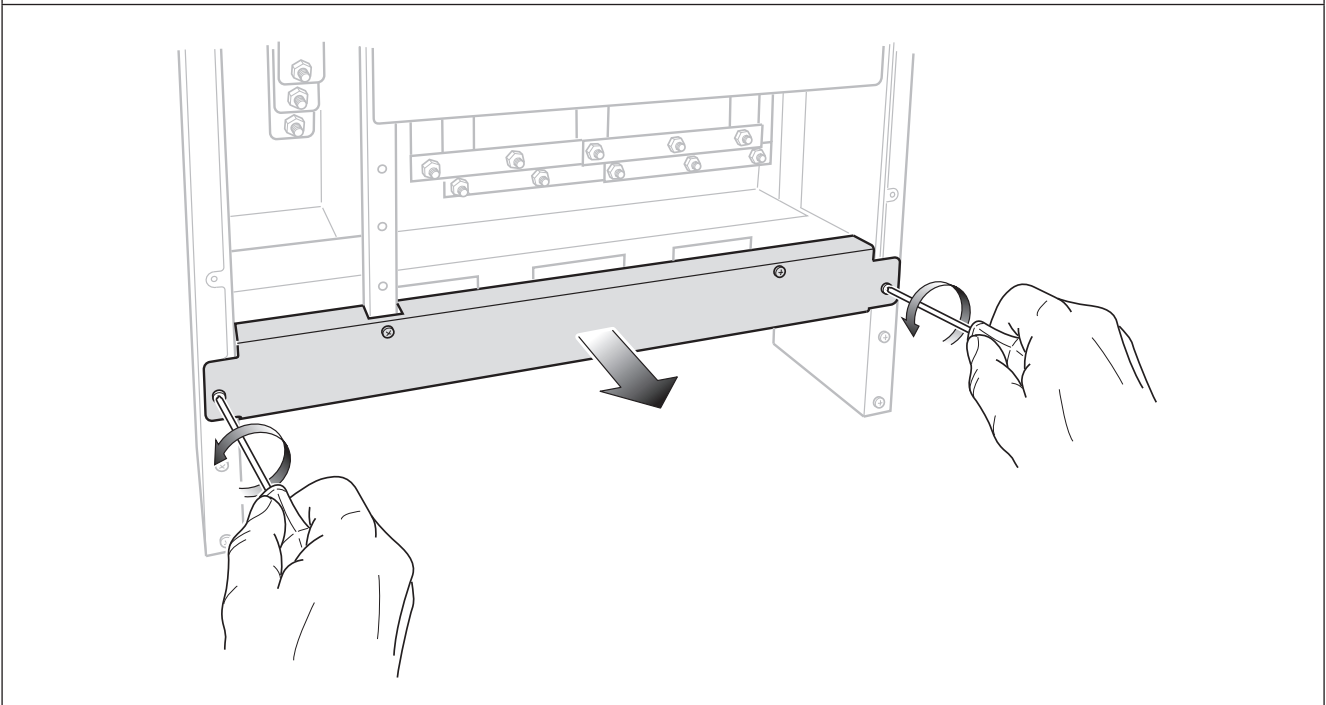

SUNSYS PCS² IM range 132 - 200 TL

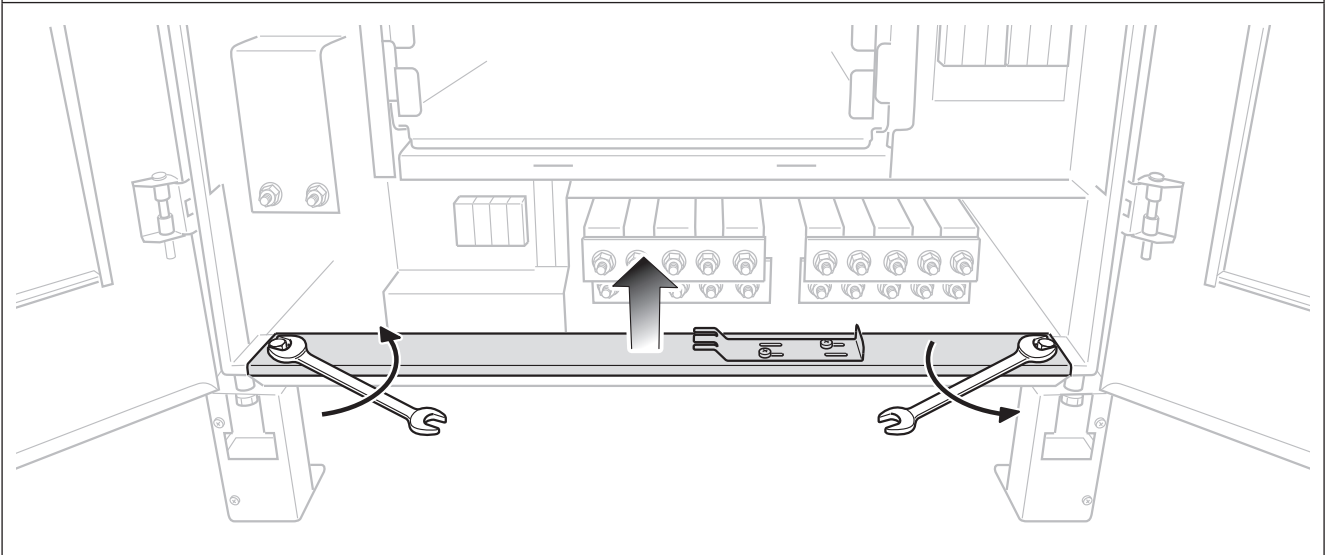

- Fix the protection wire (⊕) to the connection terminal.
- Fix the wires L1, L2, L3, N to the connection terminals.
- Fix the wires L+,L- to the connection terminals.
- Secure the power cables supplied between the transformer cabinet and the PCS² (only for 100 TR).

- Secure the signal cables supplied between the transformer cabinet and the PCS² (only for 100 TR).
- If desired fix the cables to the cable support guide using cable strapping.

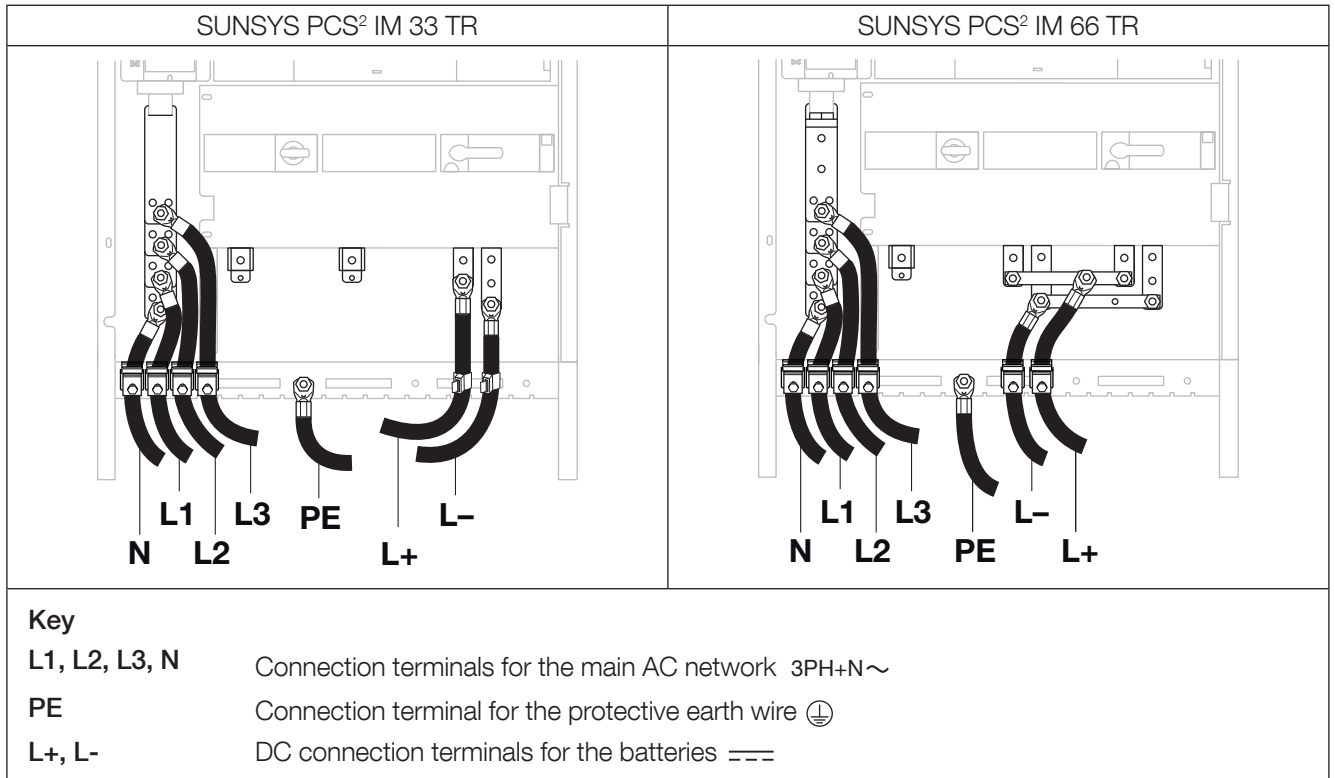

SUNSYS PCS² IM 100 TR

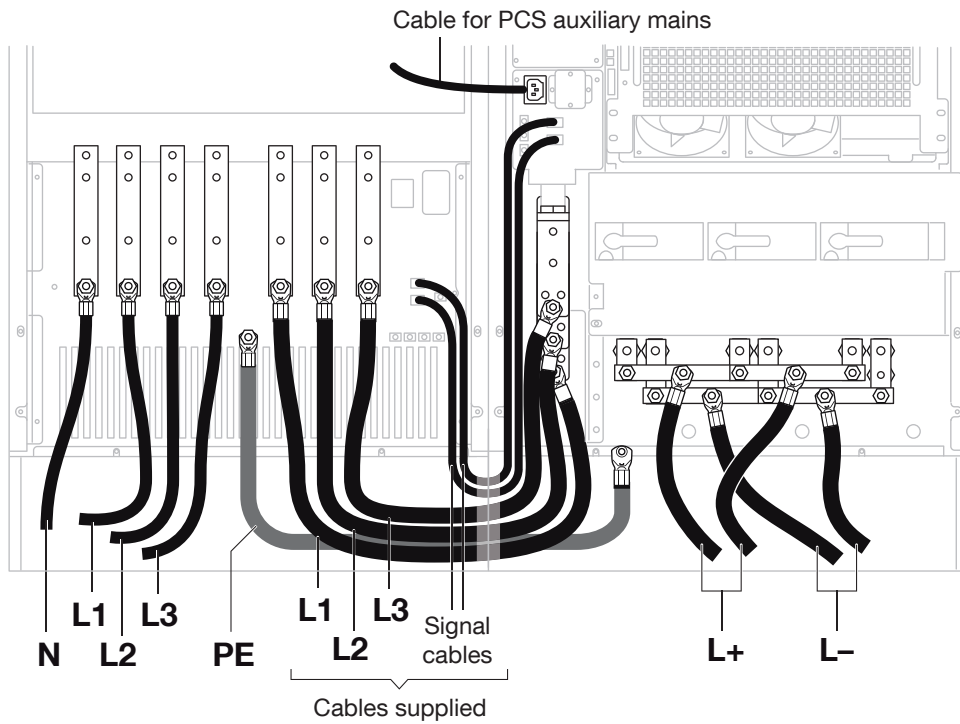

Key

L1, L2, L3, N Connection terminals for the main AC network 3PH+N~

⊕ Connection terminal for the protective earth wire ⊕

L+, L- DC connection terminals for the batteries ==

SUNSYS PCS² IM 132 - 200 TL

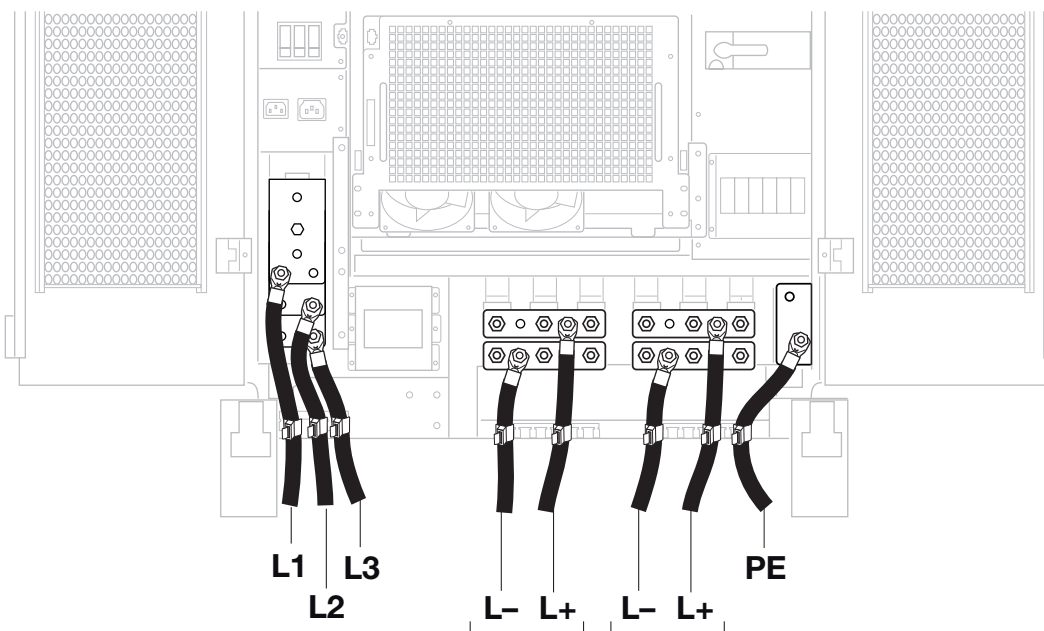

Key

L1, L2, L3 Connection terminals for the AC mains - 3 phase

⊕ Connection terminal for the protective earth wire ⊕

L+, L- DC connection terminals for the batteries ==

- Replace the horizontal support.

- Replace the panels protecting the connection area in front of the terminals.



For safety reason, the mounting of the protecting panels is compulsory.

- Fix the front base.



For safety reason, the mounting of the protecting panels is compulsory.

SUNSYS PCS² IM range 33-66-100 TR

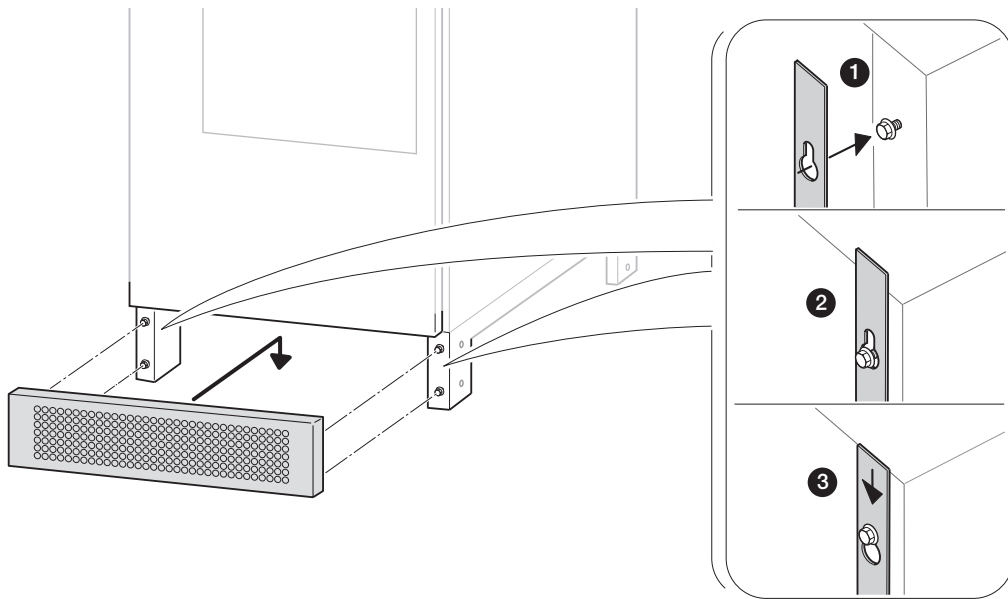

SUNSYS PCS² IM 132 - 200 TL

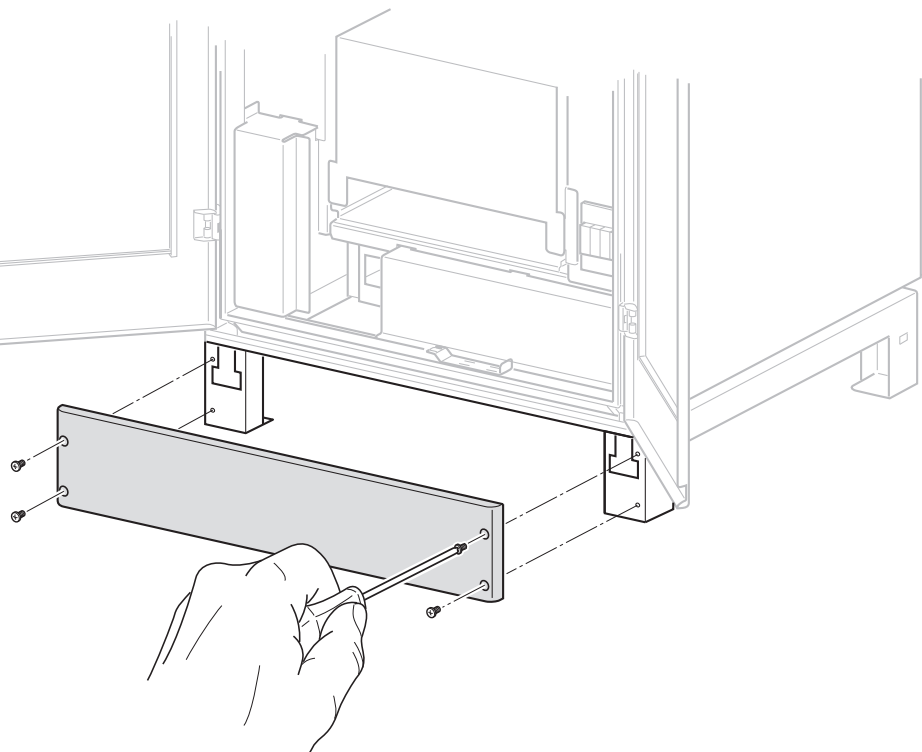

- Fix both the lateral bases

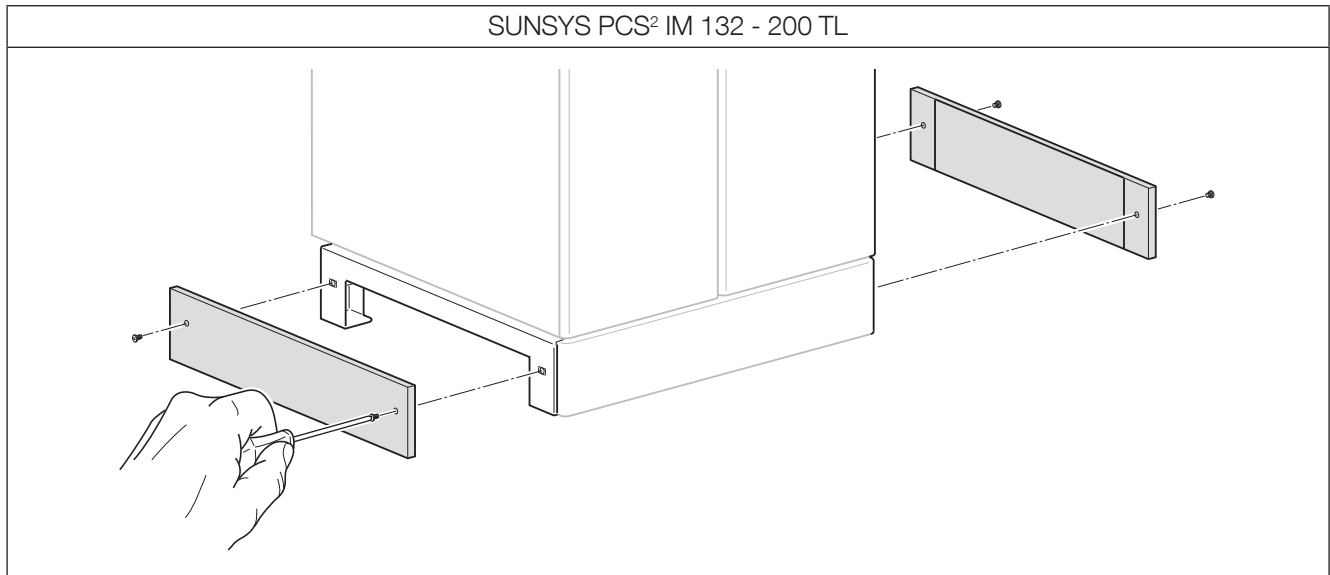

AUXILIARY CONNECTION

The SUNSYS PCS² equipment is powered by a special single-phase voltage (refer to 'Technical specifications' chapter). The auxiliary voltage must be connected to the relevant socket.



WARNING: risk of damage to the system if not observed!

SUNSYS PCS² IM 33-66-100 TR

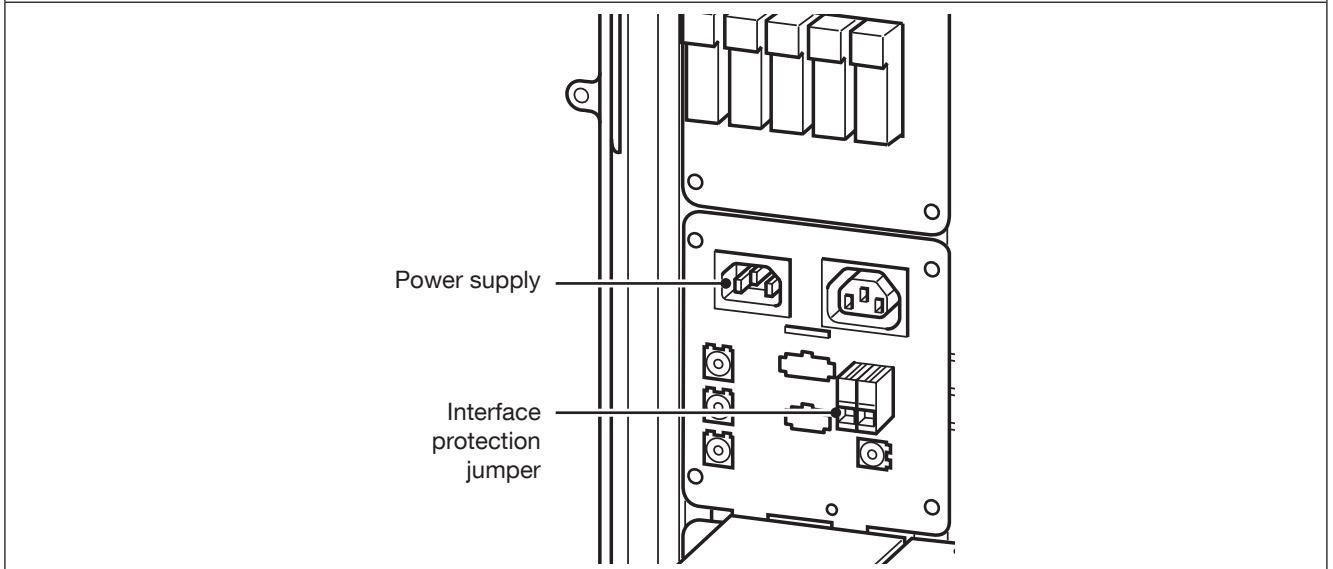

OPTIONAL INPUT FOR EXTERNAL INTERFACE PROTECTION

If local electricity company connection rules specify that external interface protection must be used, the external protection output signal (dry contact) can be used to control the internal contactor for the SUNSYS PCS² IM, removing the jumper in the diagram.



NOTE: the auxiliary power supply cable must be fitted with a 10 A max. protection device.

SUNSYS PCS² IM 132 - 200 TL



NOTE: the auxiliary power supply cable must be fitted with a 10 A max. protection device.

8.2 INSTRUCTIONS FOR SUNSYS PCS² IM 200 TL

The SUNSYS PCS² IM TL versions require the installation of a transformer coupling to the mains, in addition to the AC input protection.

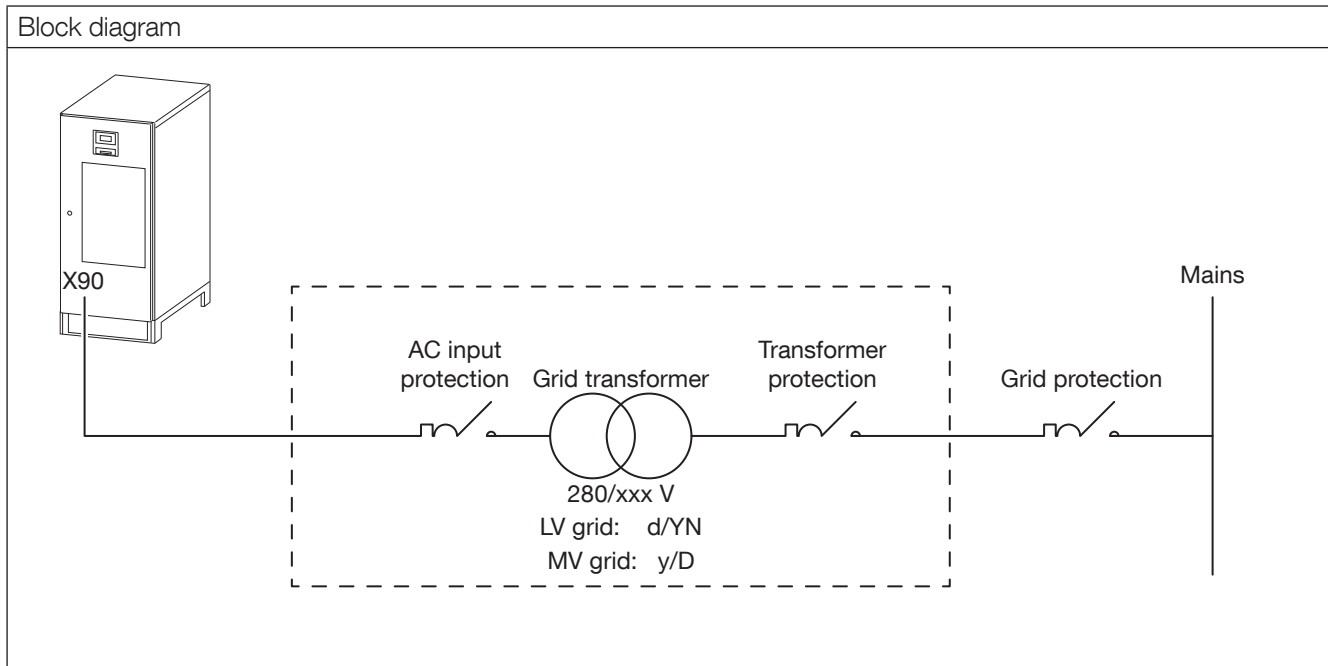

AC INPUT PROTECTION

Refer to 'Electrical installation' chapter.

GRID TRANSFORMER

The transformer is necessary to connect the PCS² IM to mains.

The main technical characteristics are outlined in the following specification.

Ratings		
Parameter	132 TL	200 TL
Rated power	140 kW	210 kW
Rated frequency	50 Hz	
Number of phases	3	
Winding connection unit	LV=> YNd MV=> Dy	
Primary voltage - grid side	Same of grid voltage (LV => Y+N MV => D)	
Secondary voltage - PCS side	280V (LV => d MV => y)	
Grid voltage range	+10% / -10%	
Primary rated current - grid side	Depends on grid voltage	
Secondary rated current - PCS side	285.8 A	433 A
Shielded	Yes Between primary and secondary winding, connected to ground.	
Overvoltage category	Depends on grid overvoltage category	

TRANSFORMER PROTECTION

The transformer protections must be chosen by the installer or plant designer.

9. CONTROL PANEL

The control panel displays information regarding operating status, electrical measurements, access to control functions and configuration parameters. It includes a colour graphic display and a luminous status bar.

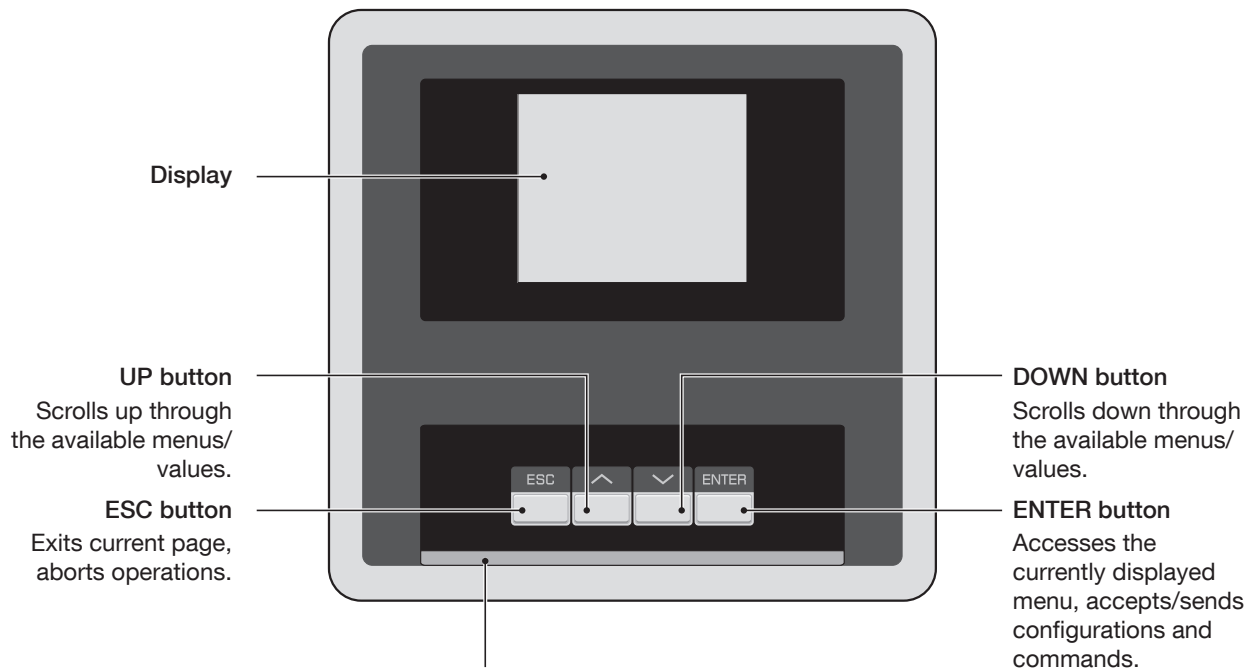

LUMINOUS STATUS BAR

Changes colour according to SUNSYS PCS² IM status.

- **Red:** SUNSYS PCS² IM off due to alert.
- **Flashing yellow:** at least one warning is present and SUNSYS PCS² IM is switched on.
- **Yellow:** at least one warning is present and SUNSYS PCS² IM is switched off or first maintenance period has elapsed.
- **Flashing green:** SUNSYS PCS² IM in startup procedure phase.
- **Green:** SUNSYS PCS² IM switched on.

9.1 EXCEPTION FOR PCS² IM 132 - 200 TL

The PCS² IM 132 - 200 TL has two control panels:

- the upper one controls the upper three power modules (Module A, Module B, Module C).
- the lower one controls the lower three power modules (Module D, Module E, Module F).

So, the first start-up procedure must be applied to both control panels ('First start-up' chapter) and both have to be used to monitor measurements, alarms, etc. ('Menu' chapter).



NOTE: in PCS² 132 TL, module A and D are not present.

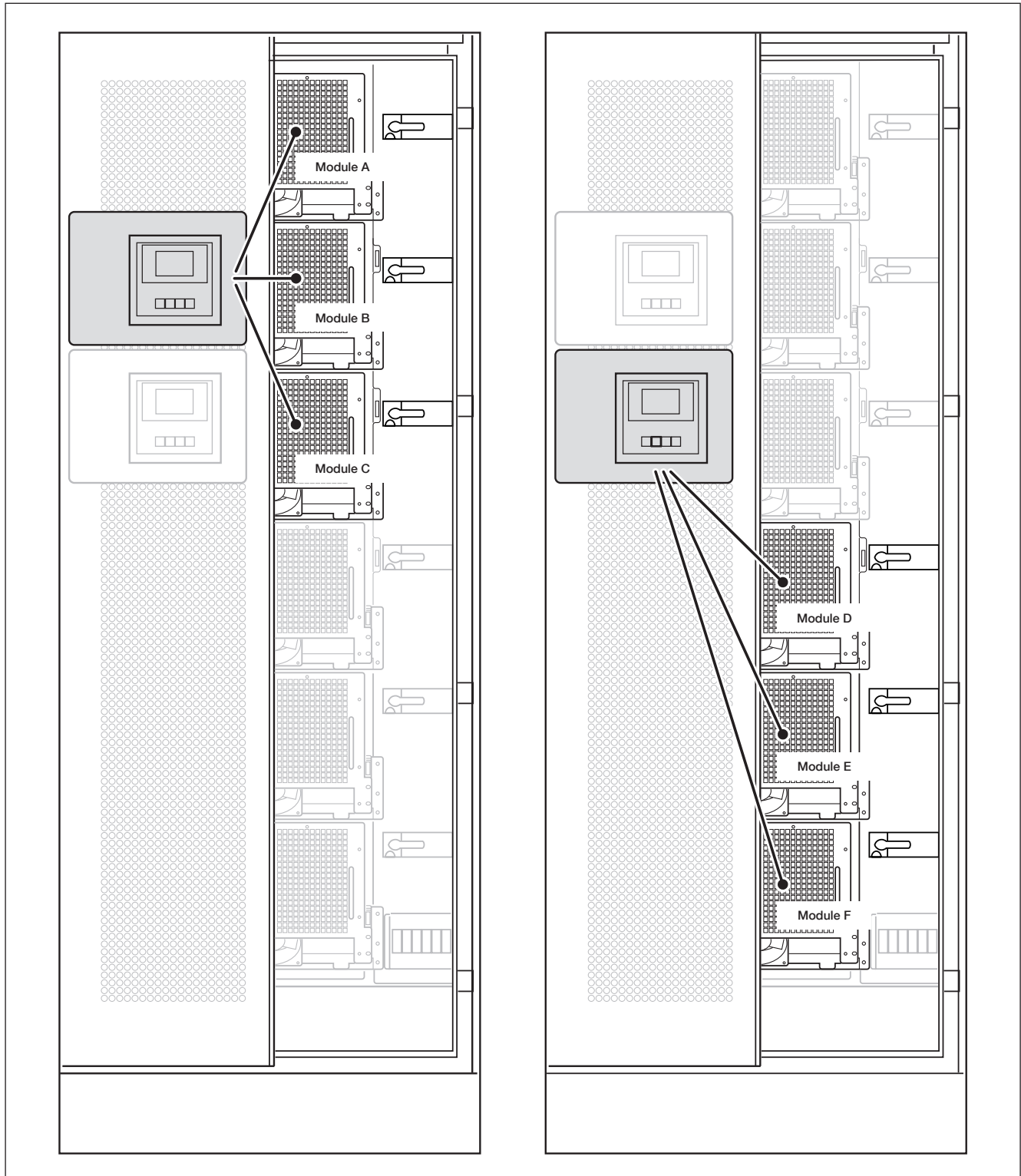

9.2 CONVERTER STATE MACHINE

The SUNSYS PCS² IM implements the following state-machine concept:

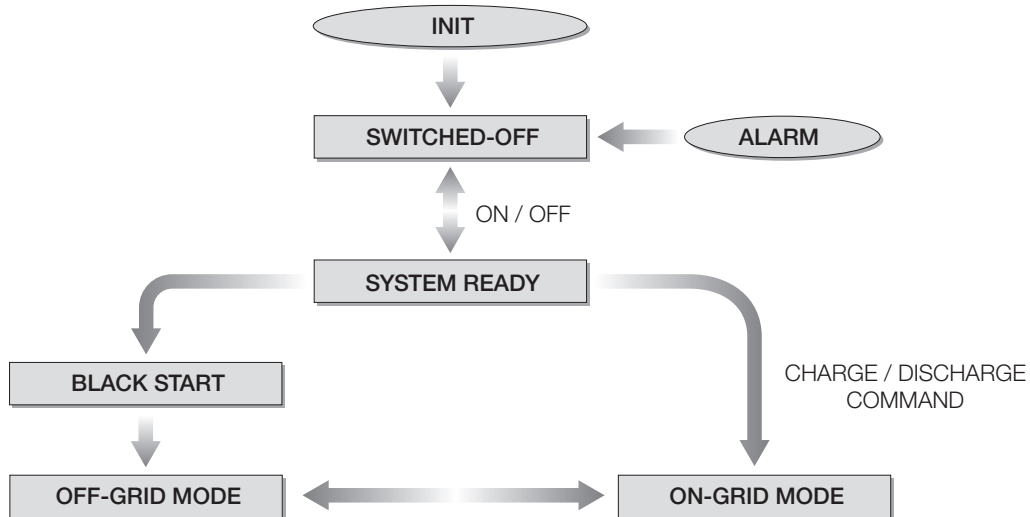

At system power-on by the auxiliary power supply, the SUNSYS PCS² IM automatically enters the **SWITCHED-OFF** status: the Control Panel shows the message SWITCHED-OFF on the Status line on the display and the luminous status bar is switched-off.

An *ON* command connects the DC source to the SUNSYS PCS² IM and it enters the **SYSTEM READY** status, after checking the battery conditions are satisfactory. On the control panel, the battery icon is green (or yellow if a Battery Warning is present⁽¹⁾) and the number of powered-on power modules appears.

The system can then operate in two modes, following two different paths:

- OFF-GRID MODE, operating in islanding conditions, as a grid-former;
- ON-GRID MODE, grid-tied and operating as a grid-follower.

From the SYSTEM READY status, a **BLACK START** procedure can be performed, in order to energise an isolated micro-grid by the battery system. After the black start procedure has completed, the SUNSYS PCS² IM enters **OFF-GRID MODE** status, generating the proper voltage and frequency references for the micro-grid.

From the SYSTEM READY status, with a *Charge/Discharge* command, the SUNSYS PCS² IM synchronizes and connects to the AC grid and enters **ON-GRID MODE** status. The SUNSYS PCS² IM follows P/Q references coming from an external control device.

The direction of the power flow on the display shows the instantaneous charging/discharging operation. The message INVERTER ON is displayed on the Status line on the display and the luminous status bar is switched-on with a green or flashing yellow light (if at least one warning is present⁽¹⁾).

Transitions from OFF-GRID MODE to ON-GRID MODE and vice versa are supported by the SUNSYS PCS² IM: additional external devices and components shall be provided (e.g. synchronisation device, circuit breaker, measurement system). Contact SOCOMEC for further information.

In the event of an alarm, the system enters **ALARM** status and switches-off to ensure conditions are safe. The luminous status bar is switched-on with a red light and an alarm message appears on the display panel.

1. A Warning does not cause the ESS to stop.

10. FIRST START-UP

 Before carrying out any operations on the unit read the 'Safety standards' chapter carefully.

When the SUNSYS PCS² IM is switched on for the first time the commissioning wizard is activated. The commissioning wizard is an interactive procedure that guides the user through the SUNSYS PCS² IM's first start-up procedure. The most important steps are described below.

LANGUAGE SETTING



ACTIVATION CODE

The Activation code - four-digit code - must be entered to operate the SUNSYS PCS² IM in both control panels.

 **WARNING:** If the code is not entered the 'initial startup' procedure cannot be completed and the equipment will not operate.

To get the activation code call the Service Centre and give the Serial Number, displayed on the control panel.

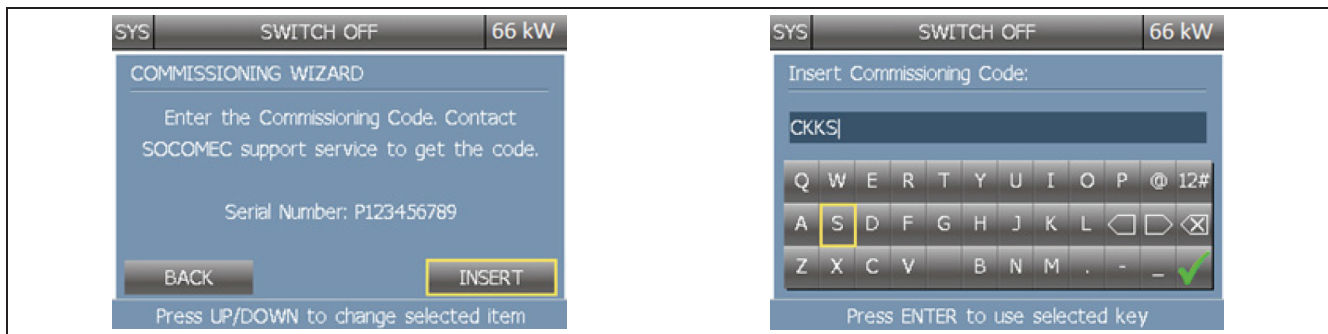

To insert the Activation Code:

- press INSERT (a screen keyboard appears);
- insert the Activation Code;
- press ✓;
- press ENTER.

DATE & TIME

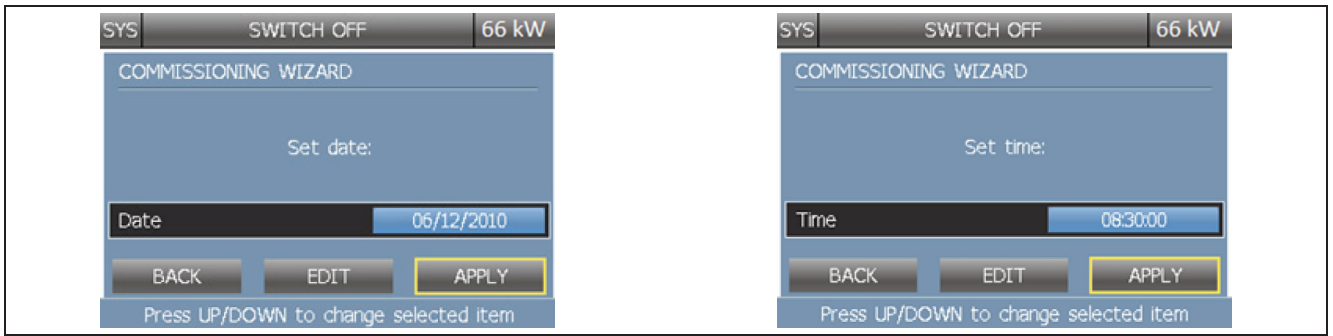

SYSTEM SETUP

Set the number of modules installed (1, 2 or 3).



TRANSFORMER TYPE

Set the type of transformer connected to SUNSYS PCS² IM.

- SOCOMEC: if standard transformer is used.
- External: if a custom transformer is provided by the customer.



BATTERY TYPE

Set the type of battery connected to the SUNSYS PCS² IM (Generic, Lithium, Lead-acid, etc.).

Depending on the type of battery, after commissioning, some specific items will be shown in the Battery Setting Menu to guarantee the correct SUNSYS PCS² IM set up.

Please complete the configuration of the battery in the Battery Setting Menu.

The list of supported batteries is subject to change without notice.



COUNTRY/GRID CODE SETTING

Set the proper country/grid code according to local regulation.

Grid code compatibility is always being upgraded, please contact SOCOMEC for grid code compatibility (subject to change without notice).



NOTE: Once the country/grid code has been set the SUNSYS PCS² will be automatically configured in compliance with the local standards.

11. MENU

11.1 DISPLAY OVERVIEW

Status bar

The screenshot shows the top portion of the SUNSYS PCS² IM display. At the top, a status bar contains 'SYS', 'SWITCH OFF', and '66 kW'. Below this, there are three main icons: a battery icon, a power icon, and a grid icon. The battery icon is labeled 'Battery Status' and 'Charge status as a %' with 'SOC 0%' below it. The power icon is labeled 'Power' with '0.0 kW' below it. The grid icon is labeled 'Grid status'. To the right of the grid icon, the time '08 44' is displayed. At the bottom of the screen, there are two buttons labeled '1' and '2', and a 'SYS' button. A message 'Press UP/DOWN to change module' is displayed below these buttons. A 'Help message area' is indicated at the bottom of the screen.

Labels and descriptions:

- ESS⁽¹⁾ Status
- SUNSYS PCS² IM Rated Power (kW)
- Energy direction
- Battery Status
- Charge status as a %
- SUNSYS PCS² IM module
- Grid status
- Instantaneous Power (kW)
- System view
- Help message area
Always present, displays a help message to guide the user through the display functions.

1. Energy Storage System (includes SUNSYS PCS² IM and Battery System).

Alarms area

The screenshot shows the same display as above, but with a red bar at the top containing the text 'A00: GENERAL ALARM'. This bar is labeled 'Alarms area'.

Labels and descriptions:

- Alarms area
Present when an alarm is active.
Enter ALARMS menu to display the complete alarms list.

Status icons





The screenshot shows the same display as above, but with several icons in the top left corner: a network icon, a modem icon, a USB icon, a key icon, and a commissioning code icon. These icons are labeled with their respective functions.

Labels and descriptions:

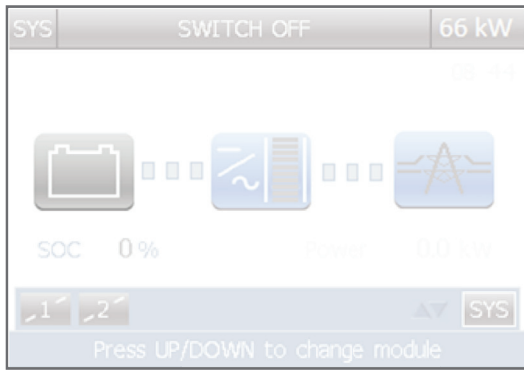
- Time: SUNSYS PCS² IM current time.
- Commissioning Code not inserted or Scheduled Inspection warning: machine inspection required. Call SOCOMEC support service
- Key icon: Displayed if the keypad has been locked.
- USB icon: Displayed if a USB memory stick is inserted. It must be formatted with a FAT32 file system.
- Modem icon: reserved for technical service.
- Network icon: Displayed if a valid link has been established on the ethernet. Flashes when a remote host is communicating with the SUNSYS PCS² IM.





SUNSYS PCS² IM Status

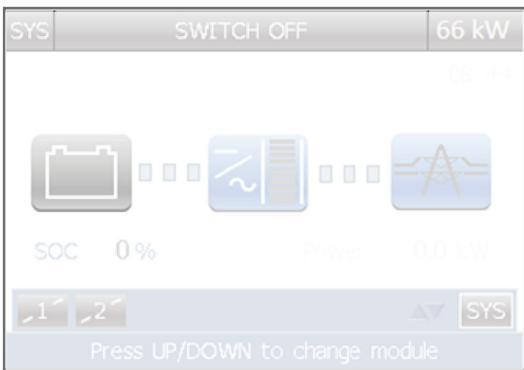

-  (grey icon) Battery not present
-  (green icon) SUNSYS PCS² IM normal operation
-  (yellow icon) SUNSYS PCS² IM warning flagged
-  (red icon) SUNSYS PCS² IM alarm flagged









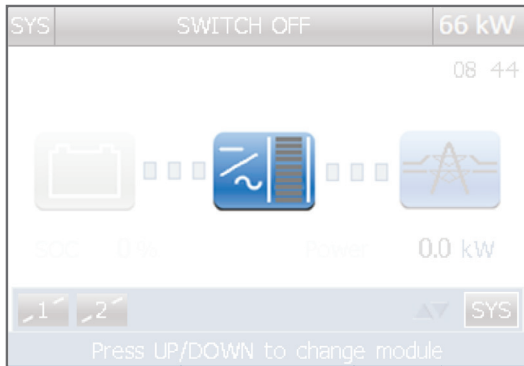

Battery status



-  SOC $\geq 87.5\%$
-  $62.5\% \leq \text{SOC} \leq 87.5\%$
-  $37.5\% \leq \text{SOC} \leq 62.5\%$
-  $12.5\% \leq \text{SOC} \leq 37.5\%$
-  SOC $\leq 12.5\%$

Instant power level



- | | | | | |
|---|---|---|---|---|
|  |  |  |  |  |
| $\leq 10\%$ | $\leq 20\%$ | $\leq 30\%$ | $\leq 40\%$ | $\leq 50\%$ |
|  |  |  |  |  |
| $\leq 60\%$ | $\leq 70\%$ | $\leq 80\%$ | $\leq 90\%$ | $> 90\%$ |

Grid status

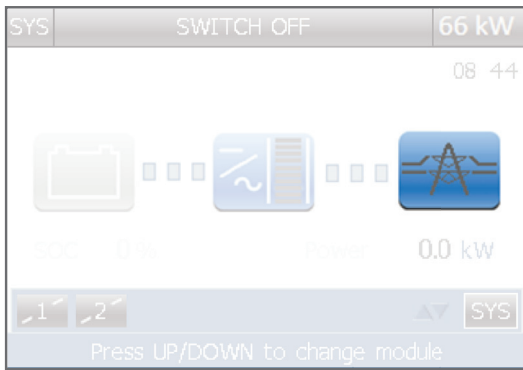

On-Grid mode



Off-Grid mode



Black-Start in progress

Local command

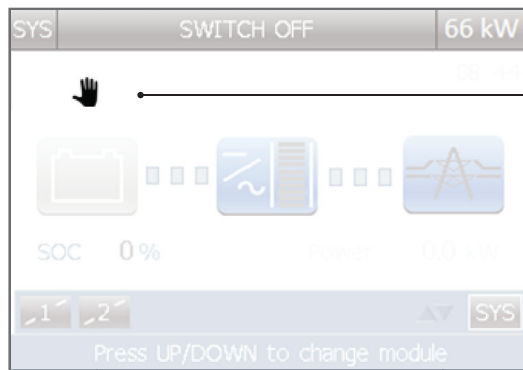

Local Command
charge/discharge sequence



NOTE: the procedures available depend on the type of battery setting.



NOTE: the 'Stop sequence' command must be selected to change the procedure.

11.2 MENU TREE

FIRST LEVEL	SECOND LEVEL	THIRD LEVEL
STATISTICS	COUNTERS	
	PRODUCTION GRAPHS	DAILY TREND
		DOD DISTRIBUTION
		DISCHARGE DURATION
		BATTERY TEMPERATURE
MEASUREMENTS	PCS POWER	
	AC MEASURES	
	BATTERY MEASUREMENTS	
	SENSORS	
ALARMS AND WARNINGS	ALARMS	
	WARNINGS	
HISTORY LOG		
COMMANDS	LOCAL PROCEDURE	Start charge/discharge ⁽⁵⁾
		PCS calibration ⁽⁶⁾
		Stop procedure ⁽⁶⁾
	ALARM RESET	Alarm reset
	TEST PROCEDURES	Led bar test
		AC contactors test
		Start fan test
	RESET STATISTICS	Reset all production data
RESTART DISPLAY	Restart display	
SISTEM CONFIG	Start config procedure	
SETTINGS	PREFERENCES	LANGUAGE
		DATE AND TIME
		BUZZER
		DISPLAY
		PASSWORDS
	SYSTEM CONFIGURATION	Local/remote control
		N° of modules
		Transformer type
		AC Interface Protection [Internal/External]
		Energy saver mode
	PCS SETTINGS	NOMINAL VOLTAGE/FREQUENCY
		COUNTRY/NETWORK CODE
		CONNECTION PARAMETERS
		EQUIPMENT PROTECTION THRESHOLDS
		Additional items depending on the Country/ Network Code selection
	BATTERY SETTINGS ⁽¹⁾	BATTERY TYPE
		BATTERY PARAMETERS ⁽²⁾⁽³⁾
		BATTERY PARAMETERS MODE ⁽³⁾
		CHARGE THRESHOLDS
		DISCHARGE THRESHOLDS
		MAINTENANCE PARAMETERS ⁽²⁾
		SOH CALCULATION ⁽²⁾
		OPTIMIZATION MODE ⁽⁴⁾
	ADVANCED CONFIGURATION	
	OPTIONAL DEVICES	OPTIONAL DEVICES 1
		OPTIONAL DEVICES 2
	CONNECTIVITY	PERIPHERALS
SERVICES		

FIRST LEVEL	SECOND LEVEL	THIRD LEVEL
SERVICE	PCS DESCRIPTION	
	FIRMWARE VERSION	SYSTEM
		MODULE1
		MODULE2
		MODULE3
	SERIAL NUMBER	
	COMMISSIONING CODE	
	UPGRADE FIRMWARE	UPGRADE HMI FIRMWARE
UPGRADE LANGUAGES		

1. Password protected.
2. Shown only if Lead-Acid battery type is set.
3. Shown only if generic battery type is set.
4. Shown only if Lithium Samsung or Lithium Saft is set.
5. Access is allowed if Local mode is enabled: SETTING > SYSTEM CONFIGURATION > Local/remote control

KEYPAD LOCKING

The keypad can be locked by pressing the buttons in the following sequence:

ESC > UP > DOWN > ENTER

To unlock the keypad the buttons must be pressed in the reverse sequence:



ENTER > DOWN > UP > ESC

These sequences only work on the Mimic Panel page.

ENTERING PASSWORDS

Some operations and settings require a password in order to be performed.

If this is the case, a padlock is displayed. When a password is required, a virtual keyboard is displayed. After inserting a valid password, the padlock opens and the operation can be performed. The default password is **SUNS**.

	<p>WARNING: the password protects important settings and parameters which are essential for correct SUNSYS PCS² IM operation.</p> <p>Only skilled and qualified technicians are allowed to access the protected parameters. Incorrect settings may damage the equipment.</p>
	<p>NOTICE: It is advisable to change the password to prevent unauthorised access.</p>

11.3 MENU DESCRIPTION

DISPLAY MENU

It is possible to view information corresponding to individual modules on the mimic panel by selecting the SUNSYS PCS² IM serial number.

LANGUAGE UPGRADE

The SUNSYS PCS² IM is delivered with the following built-in languages: English, French, Italian, German, Spanish. Further language packages can be provided by SOCOMEC, in case new markets are approached.

Text translations are held in files with the *.lng extension which are provided by SOCOMEC. Language upgrades must be performed through the USB port, using a standard USB memory stick. The USB device must be formatted with FAT16 or FAT32.

Step 1

The language file to be installed must be copied onto a USB stick and placed in the standard folder:

{USB stick}\socomec\wghi

Step 2

Insert the USB stick into the USB port on the back of the SUNSYS PCS² IM door.

Step 3

Enter the menu: SERVICE > UPGRADE FIRMWARE > UPGRADE LANGUAGES. The SUNSYS PCS² IM has to be selected beforehand on the main page.

Step 4

The list of files in the \socomec\wghi folder in the USB memory stick is shown. Select the file you want to install and follow the instructions displayed.

Step 5

At the end of the process select Yes to restart the display.

Step 6

Remove the USB stick when requested.

Step 7

The new language is available after restarting.

To change the language go to the SYSTEM menu: SETTINGS > PREFERENCES > LANGUAGE.

To restore English as the default language press the ESC button for at least 4 seconds on the main page (mimic panel page).

STATISTICS MENU

This menu displays the COUNTERS and the PRODUCTION GRAPH:

- Counters store the Running Time [Hrs] and the Tot. Num. Of Cycles.
- Production graph illustrates the:
 - Daily Trend, (last 7 days of SOC and Active Power).
 - Depth of Discharge Distribution, (numbers of cycles with a specific DOD).
 - Discharge Duration, (number of cycles with a specific discharge period).
 - Battery Temperature (number of working hours at specific temperature).

COMMANDS

The menu contains a list of commands that the user can activate through the display:

- Local Procedure:
 - Charge/discharge battery.
 - Stop procedure.
 - Calibration procedure of SUNSYS PCS² IM.
 - Commissioning procedure (only for Lead Acid Battery).
 - Equalisation procedure (only for Lead Acid Battery).
 - SOH estimation (only for Lead Acid Battery).

SETTINGS

This menu contains the System Configuration Parameters, all of them are password protected and it contains parameters for the PCS and battery configuration.

Please contact SOCOMEC for the correct configuration of the PCS according to the specific plant requirements.

Please contact SOCOMEC for the correct configuration of the Battery according to the specific battery installed.

12. OPERATING PROCEDURES



NOTE: before carrying out any operations on the unit read the 'Safety standards' chapter carefully.

12.1 SWITCHING ON

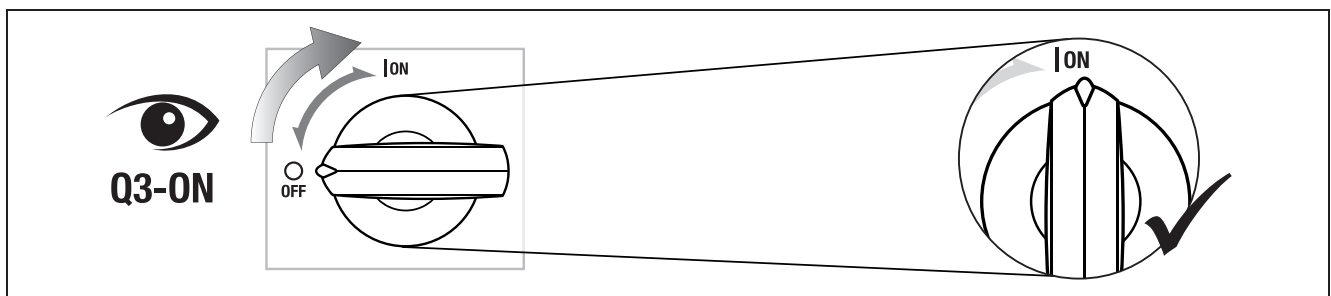
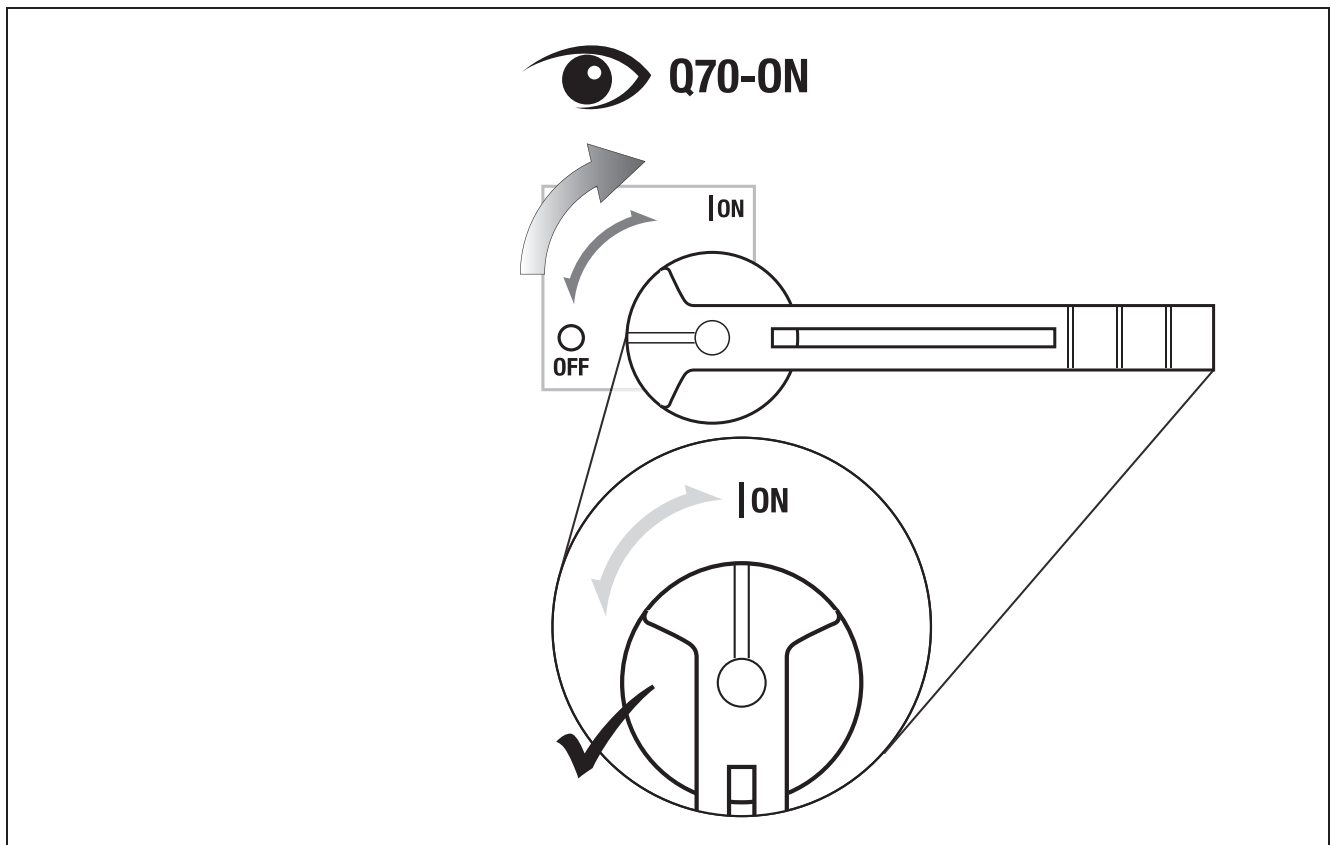
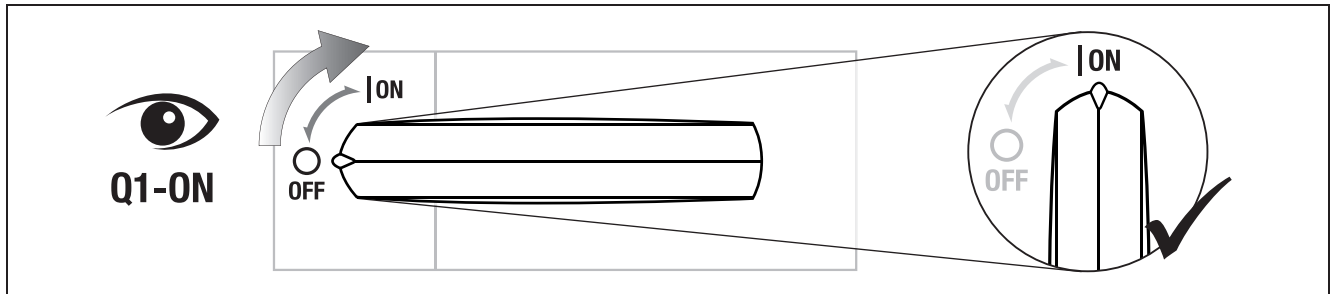

12.2 SWITCHING OFF

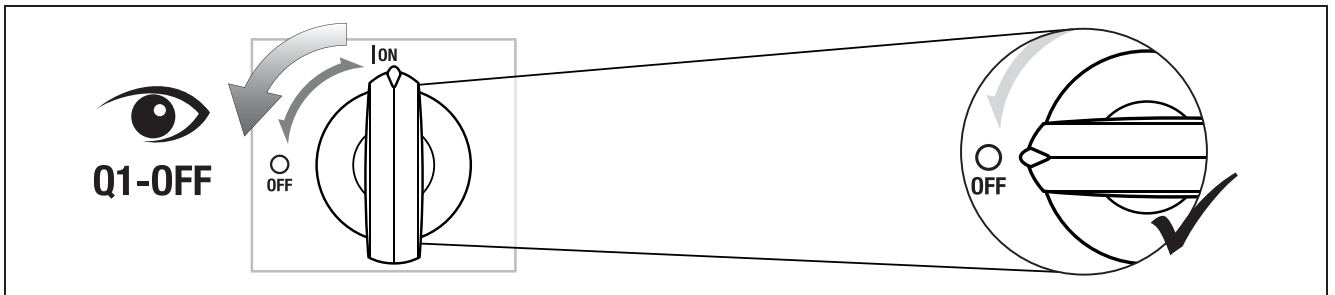
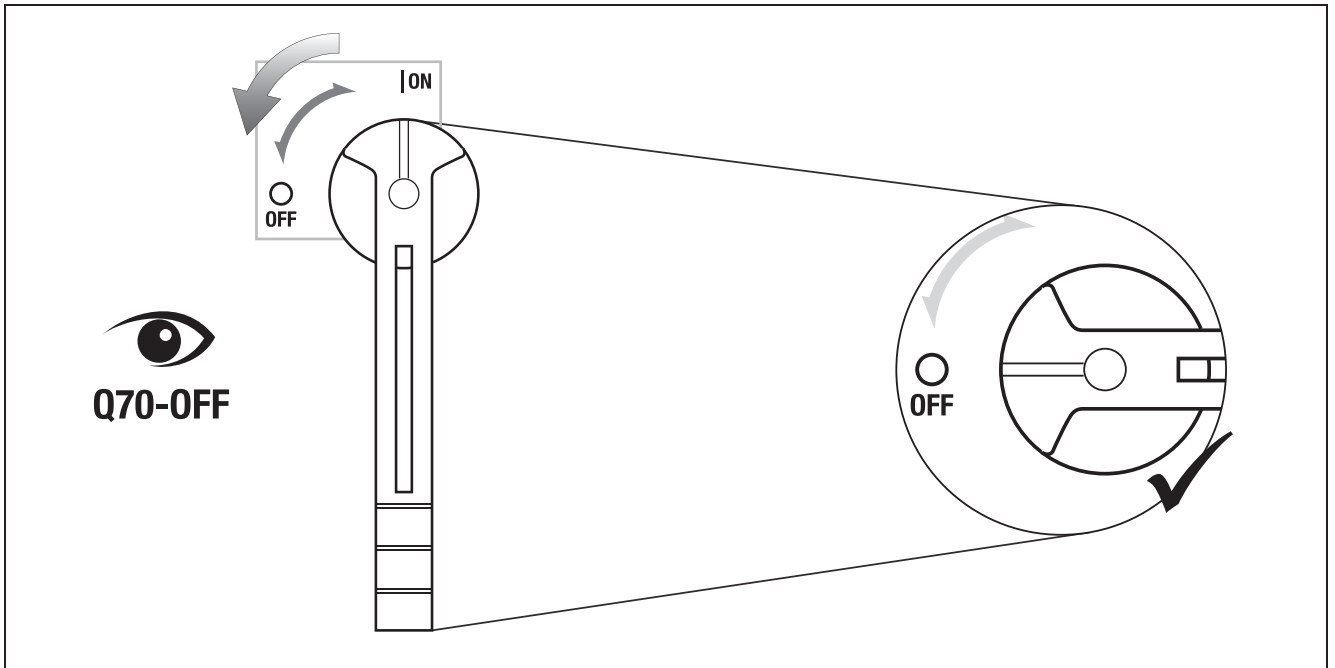
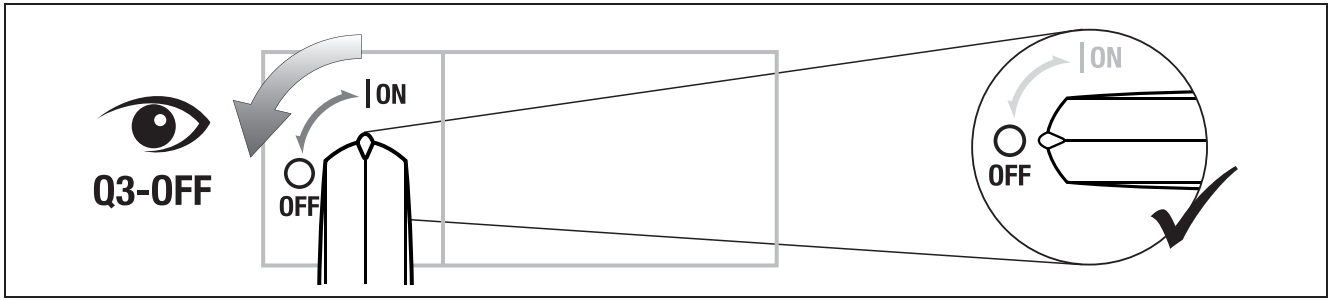

Q70 isn't present on PCS 100kW, 132kW and 200kW.

If the auxiliary power supply also needs to be cut off, disconnect the cable from the auxiliary power supply input socket or break the fuse connection.

This procedure will switch off all the auxiliary SUNSYS PCS² IM equipment, including the system controller and the control panel.

The general AC power contactor for the machine will also be opened.

13. STANDARD FEATURES AND OPTIONS

Features	Type	Description	Availability
AC surge protection devices (SPD AC)	Electrical	This feature provides protection against AC overvoltage	Available as option
DC surge protection devices (SPD DC)	Electrical	This feature provides protection against DC overvoltage	Available as option
Serial communication interface	Communication		Available as standard
Modbus TCP interface	Communication		Available as standard
ADC card	Communication		Available as standard
Communication card	Communication		Available as option

13.1 SERIAL COMMUNICATION INTERFACE

RS232/485 is a serial communication channel which can be used to connect to an external EMS or to a BMS (Battery Management System), depending on the battery type.



NOTE: RS485 cable has to be shielded.

SUNSYS PCS² IM 33-66-100 TR

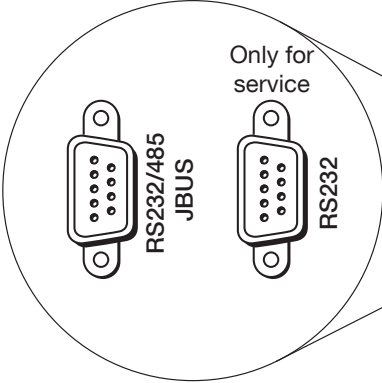

Only for service

RS232/485 JBUS

RS232

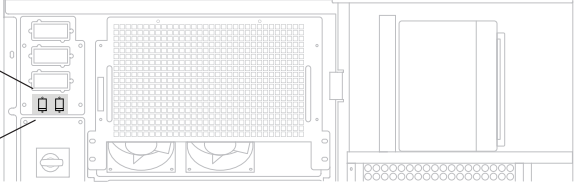

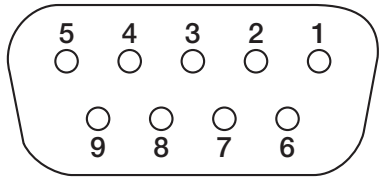

RS232/485 C1 pin key		RS232 pin key	
1	Not connected	1	Reserved
2	RX for RS232	2	RX for RS232
3	TX for RS232	3	TX for RS232
4	Data +	4	Reserved
5	GND	5	GND for RS232
6	Data -	6	Not connected
7	Reserved	7	RTS
8	Not connected	8	CTS
9	+12V	9	+12V

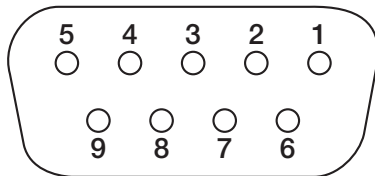
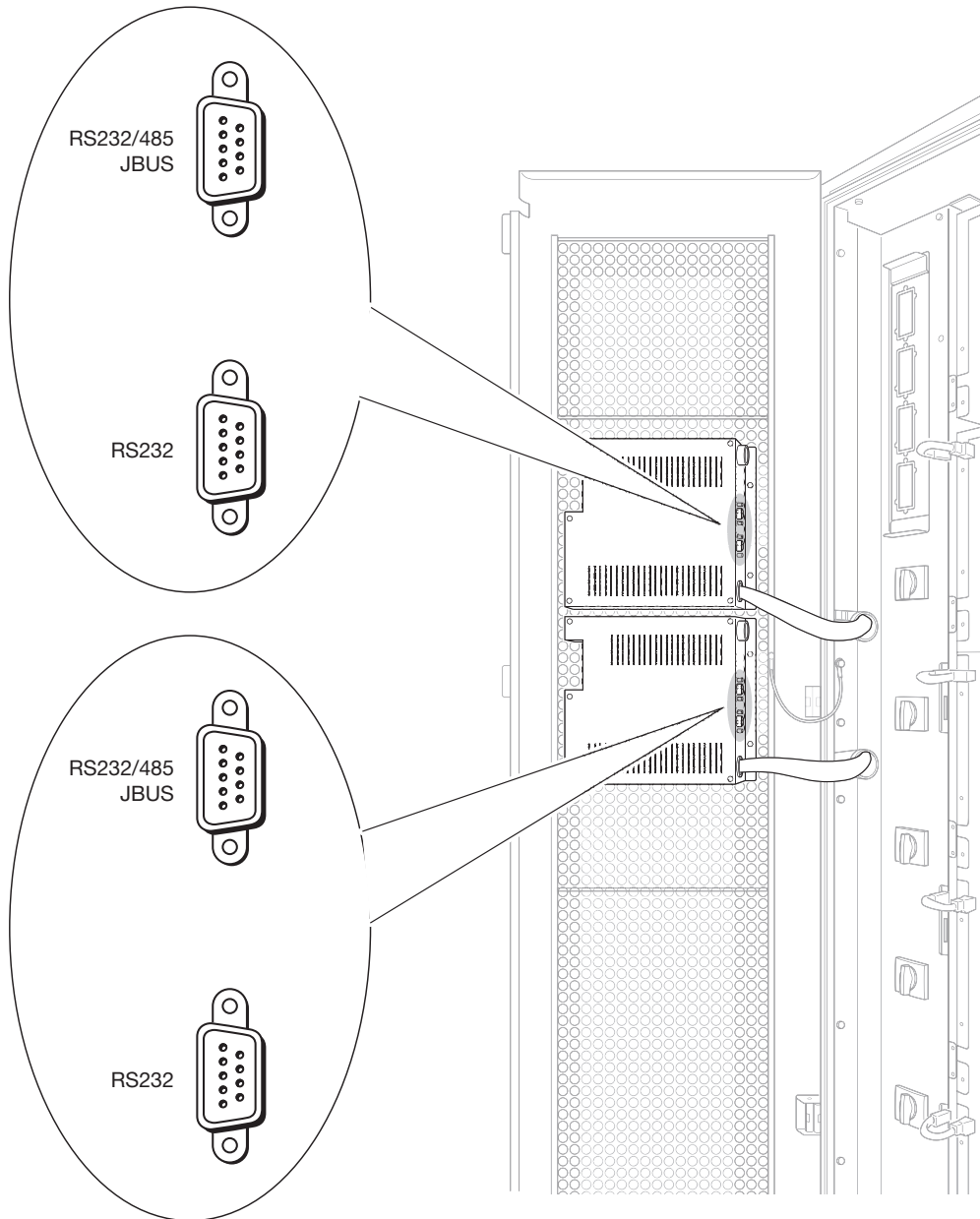

RS232/485 C1 pin key

- 1 Not connected
- 2 RX for RS232
- 3 TX for RS232
- 4 Data +
- 5 GND
- 6 Data -
- 7 Reserved
- 8 Not connected
- 9 +12V

RS232 pin key

- 1 Reserved
- 2 RX for RS232
- 3 TX for RS232
- 4 Reserved
- 5 GND for RS232
- 6 Not connected
- 7 RTS
- 8 CTS
- 9 +12V

13.2 MODBUS TCP INTERFACE

The SUNSYS PCS² IM can be managed from remote stations using MODBUS TCP network protocol. See menu **SETTINGS > CONNECTIVITY > PERIPHERALS > NETWORK PARAMETERS** to **Enable/Disable DHCP** setting. Restart the HMI after modifying the parameters. IP Addresses can be changed only if DHCP is disabled.

SUNSYS PCS² 33 - 66-100 TR

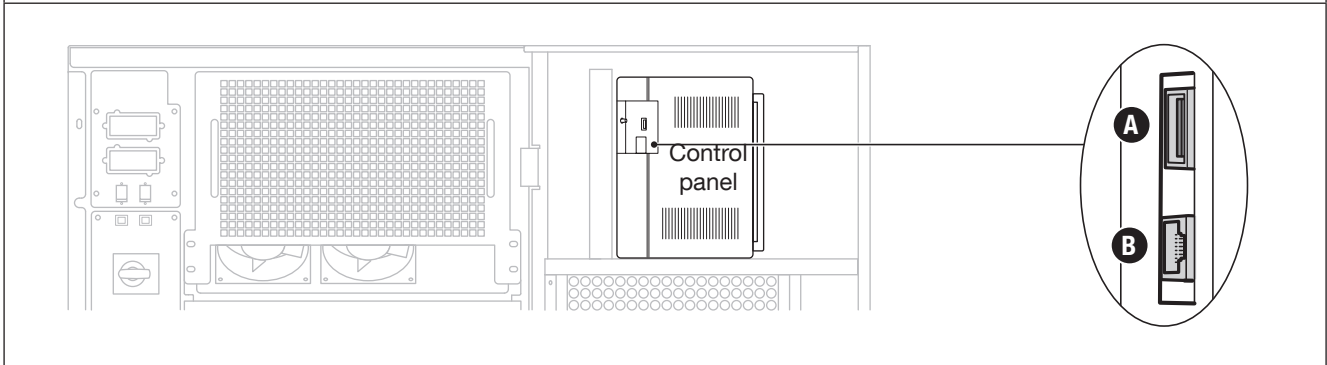

SUNSYS PCS² IM 132 - 200 TL

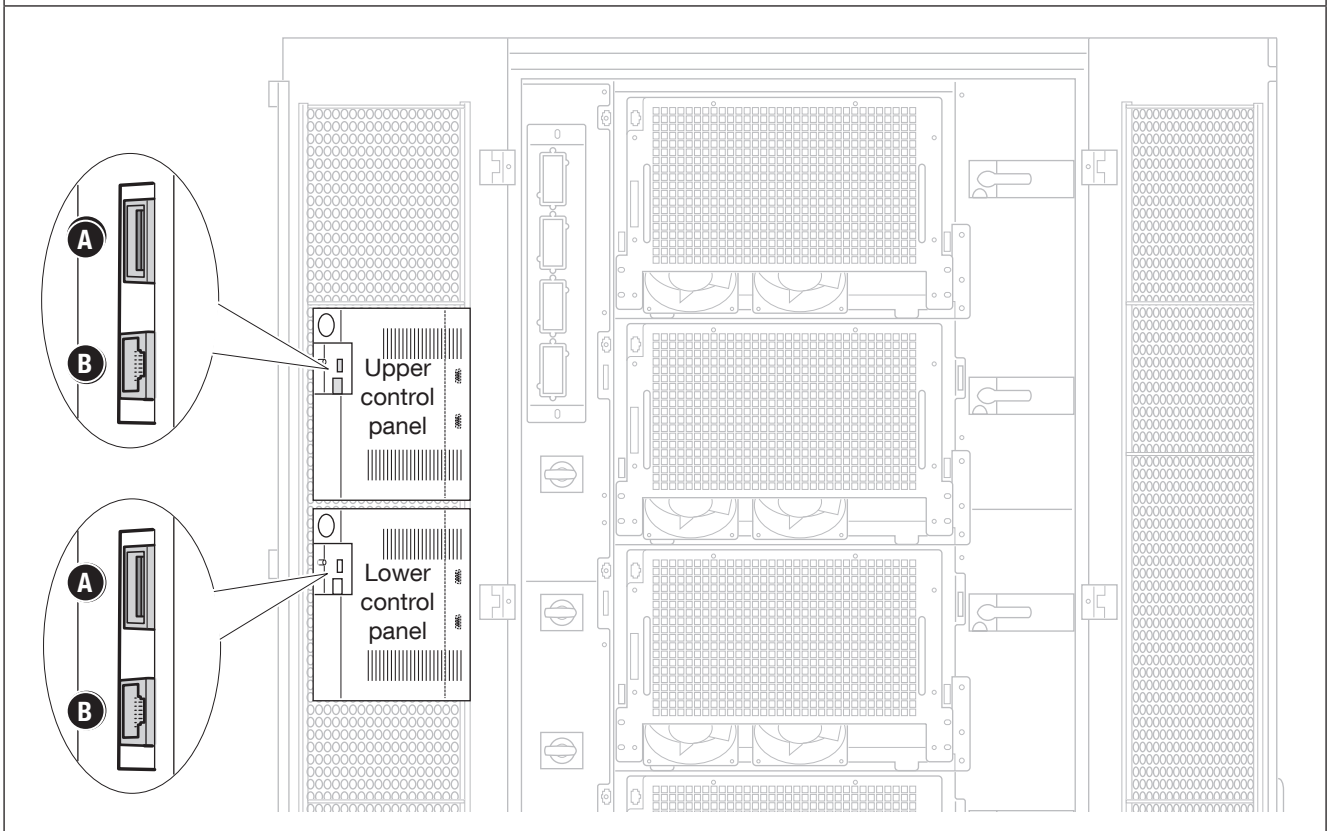

Key

- A USB connector
- B LAN RJ45 connector for ethernet



NOTE: Ethernet cable has to be shielded.

13.3 ADC CARD

This card manages four normally closed or normally open outputs and three digital inputs in configurable mode.

- Electrical data.
 - Permitted rated current and voltage of normally open or normally closed contacts: 2 A 250 Vac depending on the terminal used.
 - Inputs are activated on loop closing.
- External ESD connection.

A remote emergency shutdown system (ESD) can be installed by means of the ADC card. Connect a normally closed zero-potential contact to terminals IN1+ and IN1- of the ADC card.



Intervention of the ESD input switches off the SUNSYS PCS² IM output.

To restore the SUNSYS PCS² IM to operation:

- Close the ESD contact on 'IN 1' on the ADC board.
- Send the Alarms Reset command.

The configuration and the designation of function for the card's IN/OUT depends on the kind of batteries connected to the SUNSYS PCS² IM, whose configuration table is included in the battery cabinet manual.

The following table refers to Lead-Acid batteries only.

ADC CARD CONFIGURATION DIP1: OFF - DIP2: OFF		
IN/OUT	Description	Filter level ⁽¹⁾
OUT 1	General Alarm	0
OUT 2	DC contactor command	1
OUT 3	Battery low	0
OUT 4	Fan command	0
IN 1 ⁽²⁾	ESD	0
IN 2 ⁽³⁾	Thermal protection	2
IN 3	Temperature sensor	/

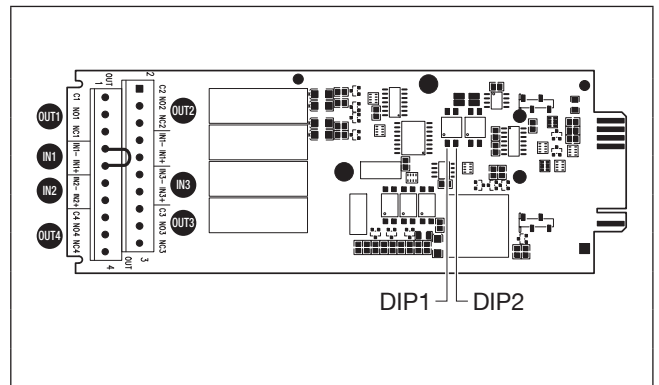

1. The filter level indicates the activation delay: 0 (no delay), 1 (1 s delay), 2 (60 s delay).
2. If the external ESD button is not used always insert a jumper to short circuit input IN 1.
3. If the external thermal protection is not used always insert a jumper to short circuit input IN 2.

If used in 132, 200 TL the ADC cards must be n°2.

13.4 SERIAL COMMUNICATION INTERFACE

Isolated Serial RS232 DB9 and RS485 connectors are available on the card.

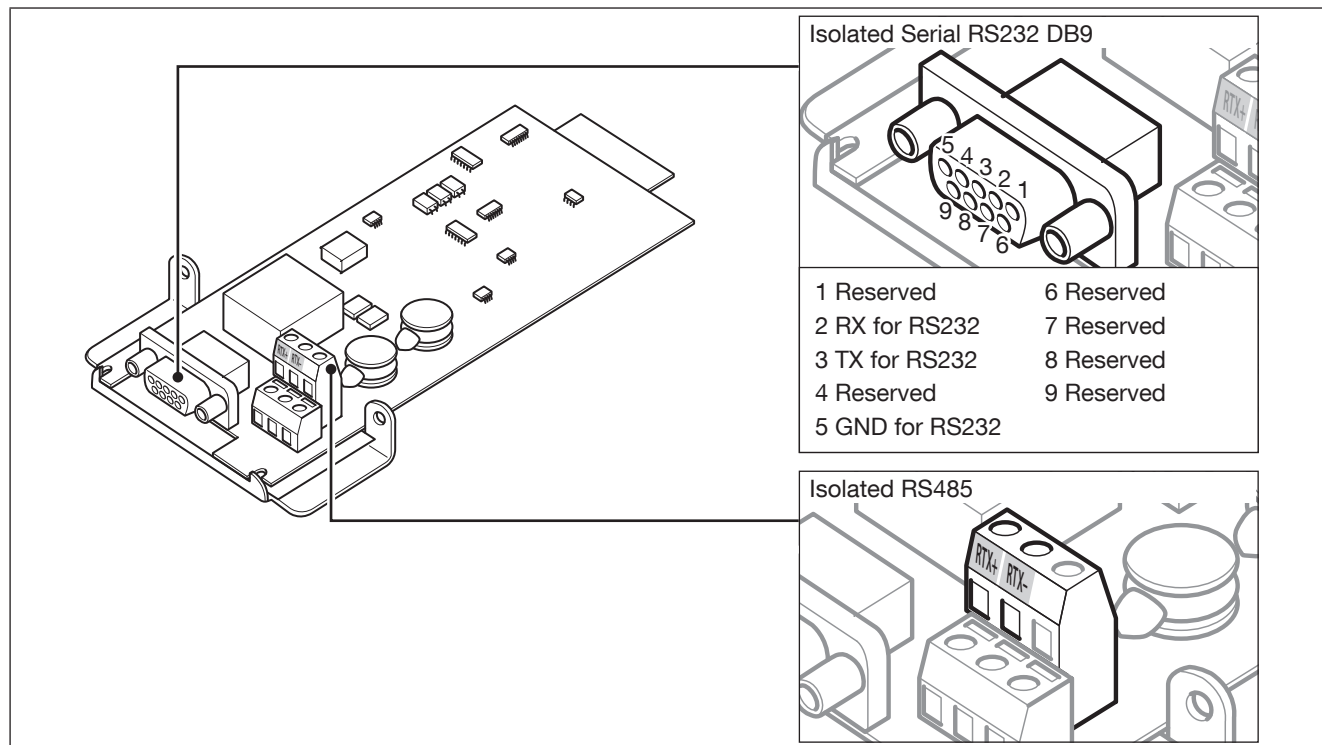

If used in 132, or 200 TL the serial communication interface cards must be n°2.

13.5 SIGNAL CABLES ROUTE

PCS² IM 132 - 200 TL

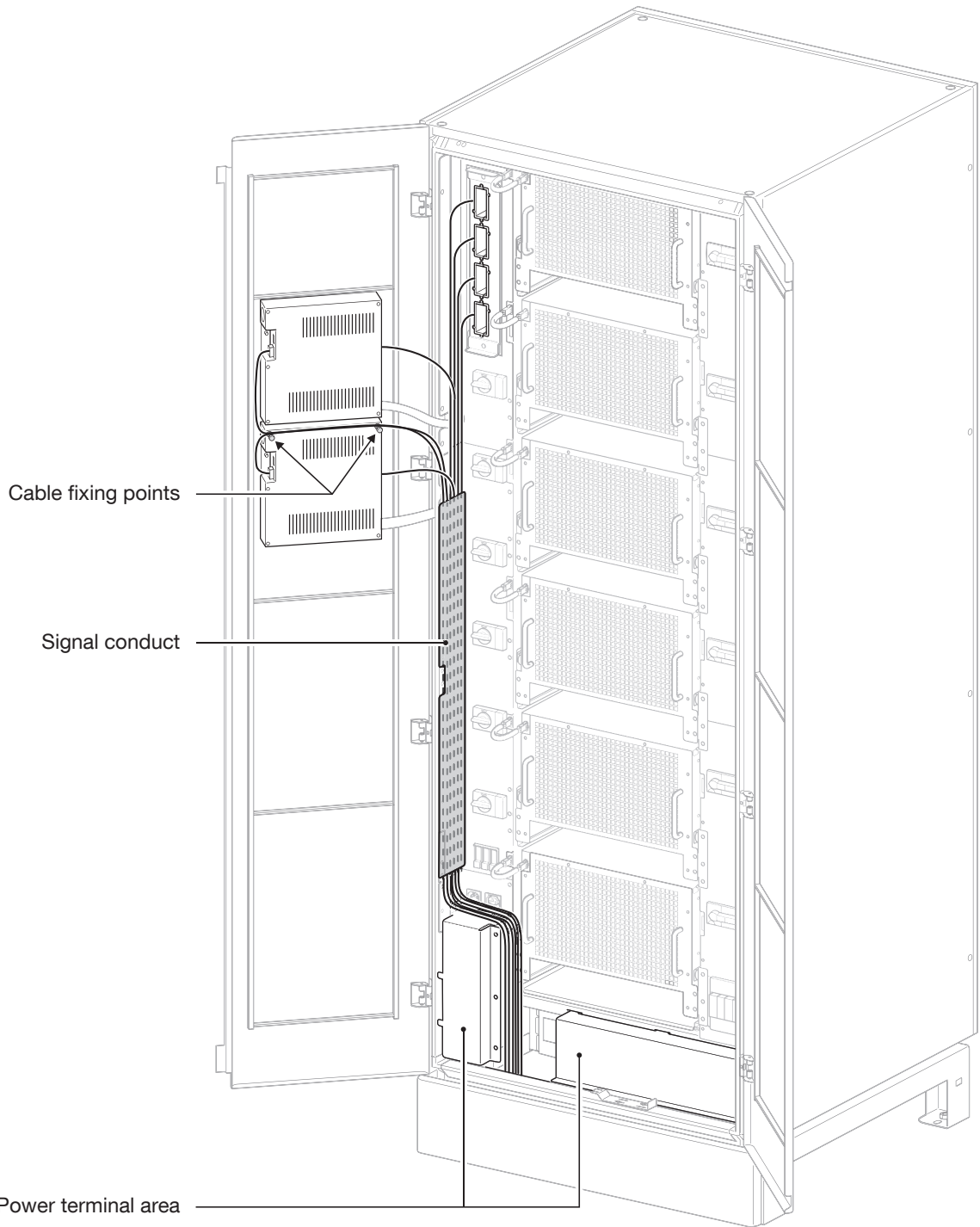

WARNING: Signal cables must not entry inside the power terminal area.

14. WARNINGS AND TROUBLESHOOTING

The alarm messages offer immediate diagnosis of any faults, malfunctions or breakdowns in the batteries.

The following events are indicated:

- Warning: non-serious alarm condition that causes the unit stop. This can be reset automatically.
- Alarm: serious alarm conditions that cause the unit stop. These alarm conditions require a manual reset.

Alarm and warnings are divided into two categories:

- System Alarms/Warnings: these alarms/warnings relate to external parts of the unit (mains power network, output line, ambient temperature). Corrective actions are activated by the user (system installer or operator) or by the Support team.
- Unit Alarms/Warnings: these alarms/warnings relate to parts of the unit. Corrective actions are carried out by the Support Service.

System warnings			
Warning		Cause	Remedy
W01	Ambient over-temperature	The ambient temperature recorded by the unit is over 45° (see values on mimic panel).	Check the ventilation or air-conditioning system in the unit room.
W02	Ambient temperature under the minimum threshold	The ambient temperature recorded by the unit is under 15° (see value on mimic panel).	Check the ventilation or air-conditioning system in the unit room.
W04	Internal over-temperature	The temperature of the unit power structure is over 110° (see value on mimic panel).	Check the ventilation or air-conditioning system in the unit room.
W66			
W20	High impedance to earth	The isolation controller and resistance to earth values recorded are too high.	Check the protective fuses. If the problem persists contact the support service.
W21 ⁽²⁾	Active Power reference too low for charging batteries	The active power set point is too low to charge battery.	Increase the value of active power set point to allow correct battery charging current.
W23	Battery fully discharged	Battery is fully discharged.	Recharge the battery.
W24 ⁽²⁾	Battery Low Voltage	Battery cell voltage is critically low.	Recharge the battery.
W25 ⁽²⁾	Battery Low Capacity	Battery charge is critically low.	Recharge the battery.
W26 ⁽²⁾	Battery Rest Time request	Battery has to wait for the Rest Time before charging/discharging.	Wait for the rest time.
W27 ⁽²⁾	Battery Full Charge request	Battery requires a Full Charge before discharging.	Full recharge of the battery.
W28 ⁽²⁾	Battery Over-temperature	Battery temperature too high.	Reduce ambient temp.
W29 ⁽²⁾	Calibration Procedure request	Execution of Calibration procedure is required.	Execute calibration procedure.
W30 ⁽²⁾	Equalisation Procedure request	Execution of Equalisation procedure is required.	Execute equalisation procedure.
W31	Local Mode Enabled	ESS is locally controlled through HMI.	Use HMI to control.
W32	General Battery Warning	Other battery warnings are present.	Solve the specific battery warning.
W33	AC input network outside voltage on frequency range	Input network is missing or insufficient (voltage and/or frequency values incorrect with reference to the information provided in the technical data table).	Check for the disconnection of protective devices upstream of the unit.
W34			Check the applied voltage and frequency comply with the values set on the HMI.
W36	Inverter overload condition	Inverter is working in overload conditions.	Reduce the load.
W77			
W38	Active power limitation	Active power request by EMS isn't satisfied (due to temperature or elapsed overload condition).	Reduce the active power request.
W81			
W39	Reactive power limitation	Reactive power request by EMS not satisfied (due to temperature or elapsed overload condition).	Reduce the reactive power request.
W82			

System warnings			
Warning		Cause	Remedy
W40	Low Insulation Resistance	Detection of low insulation resistance.	Check the Insulation to earth.
W41	Insulation Sensor Fault	Insulation sensor feedback not correct.	Check the Insulation Monitoring Device is properly connected.
W42 ⁽¹⁾	Module 1 on Alarm	Module 1 stopped by alarm.	Check Module 1.
W43 ⁽¹⁾	Module 2 on Alarm	Module 2 stopped by alarm.	Check Module 2.
W44 ⁽¹⁾	Module 3 on Alarm	Module 3 stopped by alarm.	Check Module 3.



Unit warnings			
Warning		Cause	Remedy
W65	Unit in Derating	The unit is reducing the power supplied/ drawn by the network.	Check the other alarms and/or visual warnings.
W69	AC input network outside frequency range	Input network is missing or insufficient (voltage and/or frequency values incorrect with reference to the information provided in the technical data table).	Check for the disconnection of protective devices upstream of the unit.
W70			Check the applied voltage and frequency comply with the values set on the HMI.
W81	Unit Active power limitation	Active power request by EMS not satisfied (due to temperature or elapsed overload condition).	Reduce the active power request.
W82	Unit Reactive power limitation	Reactive power request by EMS not satisfied (due to temperature or elapsed overload condition).	Reduce the reactive power request.

System alarms			
Alarms		Cause	Remedy
A01 ⁽³⁾	Switch-off due to external command	The PCS is switched off due to an external instant switch-off command.	Check if the external contact is properly connected to ADC card. A manual reset could be needed.
A05 ⁽³⁾	SPD AC triggered	AC overvoltage.	Check and replace if necessary.
A06 ⁽³⁾	SPD DC triggered	DC overvoltage.	Check and replace if necessary.
A07	Output contactor alarm	The output contactor status has not complied with machine command.	Contact the support service.
A08	Transformer over-temperature	Over-temperature of the transformer.	Check the ventilation or air-conditioning system in the unit room.
A13	Watchdog elapsed	External EMS communication watchdog elapsed.	Check the cable between PCS and External EMS device.
A15	Incorrect system configuration	System configuration wrong.	Check the configuration setting.
A22	Battery Overvoltage	Battery voltage too high.	Check the battery configuration.
A23	Battery Communication fault	No battery communications.	Check the cable between PCS and battery.
A24	General Battery Alarm	Other battery alarm are present.	Solve the specific battery Alarm.
A25 ⁽²⁾	BES Thermal protection fault	Over temperature inside the cabinet.	Check the thermal protection is properly connected to the ADC Card and verify temperature inside battery cabinet.
A26	DC Connection Fault	Battery DC Contactor test failed.	Check battery DC Contactor is properly connected to the ADC Card.
A27 ⁽²⁾	Battery Over Temperature	Battery temperature too high.	Reduce ambient temperature.

Unit alarms			
Alarms		Cause	Remedy
A68	Unit off due to over-temperature	Over-temperature cause.	Reduce ambient temperature.
A69	Fan fault	Ventilation system breakdown.	Make sure the air inlets and outlets on the front and rear of the unit are free from obstructions.
A72	Unit locked	Internal cause.	Check the specific alarm.
A73	Input over-voltage	The DC input voltage has exceeded 900 V.	Check the connections.
A76	Ambient under-temperature	Ambient temperature is too low.	Check the ventilation or air-conditioning of the unit room.
A77	Ambient over-temperature	Ambient temperature is too high.	Check the ventilation or air-conditioning of the unit room.
A78	Wrong phases rotation	Wrong AC voltage phases rotation.	Check the phases rotation upstream of the unit.
A84	AC Voltage Fault	AC voltage fault during Off-Grid operation.	Check the load or faults downstream of the unit
A85	Overload elapsed	Inverter stopped for elapsed overload.	Reduce the load.

1. Only Power Module N° (1,2,3) has flagged an alarm, but the system is still operational.
2. Shown only if lead-acid battery type is set.
3. Available as option.

15. PREVENTIVE MAINTENANCE

	NOTE: before carrying out any operations on the unit read the 'Safety standards' chapter carefully.
	NOTE: any work carried out on the equipment must be performed by qualified technicians authorised by SOCOMEC.

Routine maintenance carried out annually is recommended in order to provide optimum operating efficiency and avoid equipment downtime.

Maintenance consists of thorough functionality checks on:

- Electronic and mechanical parts;
- Dust removal;
- Software updating;
- Environmental checks.



15.1 BATTERIES

The condition of the battery is fundamental to ESS operation.

During the operating lifetime of the battery, the Sunsys PCS² stores statistics on the conditions of use of the battery for analysis.

Expected battery lifetime is very much dependent on operating conditions:

- Number of charging and discharging cycles;
- Load rate;
- Temperature.

	NOTE: batteries must only be replaced with batteries recommended or sold by the manufacturer. Batteries must only be replaced by qualified technicians.
	BEWARE: used batteries contain harmful substances. Do not open the cover!
	NOTE: used batteries must be placed in appropriate containers. They should only be entrusted to a specialist waste disposal company.

15.2 FANS & CAPACITORS

The lifespan of consumable parts such as fans and capacitors (AC and DC) depends on whether or not the use and environmental conditions (premises, usage or load type) are abnormal or harsh for the equipment.

It is advisable to replace consumables as follows⁽¹⁾:

Consumable part	Years
Fan	5
AC and DC capacitor	7

1. Based on operation of the unit according to the manufacturer's specification.

16. SAFEGUARDING THE ENVIRONMENT

Do not dispose of electrical appliances with normal waste, use separate collection facilities.

Follow local council waste regulations for proper disposal arrangements to reduce the environmental impact of waste electrical and electronic equipment or contact your local government for information regarding the collection arrangements available.

If electrical appliances are disposed of in landfills or dumps, hazardous substances can leak into the groundwater and get into the food chain, damaging health and wellbeing. Depleted batteries are considered as toxic waste. When battery replacement becomes necessary, only give rundown batteries to certified and licensed waste disposal companies. In accordance with local legislation, it is prohibited to dispose of batteries together with other industrial waste or household refuse.



The crossed-out trash bin symbol is placed on this product to encourage users to recycle components and units whenever possible. Please be environmentally responsible and recycle this product through your recycling facility at the end of its lifetime.



For any questions regarding the disposal of the product, contact local distributors or retailers.

17. TECHNICAL SPECIFICATIONS

Model		33 TR	66 TR	100 TR	132 TL	200 TL
DC Section						
Range of DC operating voltage		450 to 825 Vdc without derating 350 to 850 Vdc with derating				
Number of power modules		1	2	3	4	6
Maximum discharging current	A	80	160	240	160 + 160	240 + 240
Maximum recharging current	A	80	160	240	160 + 160	240 + 240
Battery Section						
Lithium, Lead acid, Vanadium Redox, Generic Battery		Supported in combination with PMS. Please contact Socomec for compatibility.				
AC Section						
Maximum continuous power	kW	33	66	100	132	200
Maximum continuous apparent power	kVA	33	66	100	132	200
On-grid overload		110% - 30 minutes				
Off-grid symmetrical overload		110% - 30 minutes 125% - 10 minutes 150% - 30 seconds				
Off-grid asymmetrical overload (mono phase load)		190% - 30 minutes 215% - 10 minutes 260% - 30 seconds			Not applicable	
Nominal voltage (Un)	VAC	400 (3ph + N)			280 (3ph)	
Operating voltage range	VAC	320 to 480 (3ph + N)			224 to 336 (3ph)	
Active power droop	Hz	-0.24 @ nominal kW supplied +0.24 @ nominal kW absorbed				
Reactive power droop: percentage voltage variation		+3% Vnom @ Load cosφ 0.8 cap. (neg.) -7% Vnom @ Load cosφ 0.8 ind. (pos.)			+2% Vnom @ Load cosφ 0.8 cap. (neg.) -7% Vnom @ Load cosφ 0.8 ind. (pos.)	
		+9% Vnom @ nominal kVAR cap. (neg.) -11% Vnom @ nominal kVAR ind. (pos.)			+5% Vnom@nominal kVAR cap. (neg.) -10% Vnom@nominal kVAR cap. (pos.)	
Rated frequency (Fn)	Hz	50				
Operating frequency range	Hz	47.5 to 51.5				
Rated current	A	48	96	144	272	412
Maximum current at nominal voltage	A	72	145	216	408	618
Overcurrent protection device	A	63 Type D	125 Type D	200 Type D	315 Type C	500 Type C
Off-grid short-circuit current 3-phase (Ik3 IEC60909-0) and phase-phase (Ik2 IEC60909-0)		90 A x 40 ms + 75 A x 60 ms	180 A x 40 ms + 150 A x 60 ms	270 A x 40 ms + 225 A x 60 ms	462 A x 40 ms + 383 A x 60 ms	700 A x 40 ms + 580 A x 60 ms

Model		33 TR	66 TR	100 TR	132 TL	200 TL
Off-grid short-circuit current phase-neutral (Ik1 IEC60909-0)		145 A x 40 ms + 115 A x 60 ms	290 A x 40 ms + 230 A x 60 ms	435 A x 40 ms + 345 A x 60 ms	Not applicable	
Output power factor rating		-1.00 to +1.00				
THDI On-grid mode	%	< 4				
Topology		Single conversion with Output transformer			Single conversion transformerless	
Parallel operation						
On-grid		With any kind of generator (voltage or current type)				
Off-grid		With other SUNSYS PCS ² IM (power extension)				
		With generic current/power generators				
		Not operated in parallel with isochronous voltage generator				
Other features						
Islanding detection		Yes				
Scheduled On-grid to Off-grid transition		Without break				
Capable of receiving frequency and voltage reference in islanding mode from external device (PMS)		Yes				
Capable of receiving frequency and voltage reference from external device (PMS) to synchronise the microgrid with the grid to perform off-grid to on-grid transition		Yes				
Black start mode: capable of supplying the microgrid from power cut conditions		Yes				
Efficiency						
Dissipated power (max)	W	1750	3500	5250	4820	7300
Dissipated power (max)	BTU/h	5980	11950	17900	16435	24900
Maximum efficiency	%	96.1	96.3	96.4	97.6	
Auxiliary AC power supply						
Rated voltage	VAC	230				
Rated frequency	Hz	50				
Consumption in operation	W	< 30				
Consumption in standby	W	< 10				
General data						
Pollution class in accordance with IEC 60664-1		3				
Pulse resistance voltage in accordance with EN 60060-1 AC terminals	kV	2.5				
Pulse resistance voltage in accordance with EN 60060-1 DC terminals	kV	4				
Degree of protection		IP20				
Environmental category		Non-air-conditioned indoor space				

Model		33 TR	66 TR	100 TR	132 TL	200 TL	
Operating ambient temperature	°C	-5 to +50 (40 to 50 with derating)					
Storage temperature	°C	-20 to +60					
Relative humidity	%	5 to 95 condensation-free					
Cooling system		Smart cooling					
Required cooling capacity	m³/h	480	1280	1760	1742	2880	
Acoustic noise at 1 m	dB	< 60	< 64	< 64	< 65	< 67	
Altitude (max)	m	1000					
Dimensions and Weight							
Dimensions	Width	mm	600	1200	805		
	Depth	mm	795			806	
	Height	mm	1400			2150	
Weight		355 kg	530 kg	206 + 610 kg	441	510 kg	
Power module weight		34.5 kg					
Certifications							
Safety		EN 60950-1/A2; EN 62477-1					
Product and installation		IEC 62909-1					
EMC		EN 61000-3-12; EN 61000-6-2; EN 61000-6-3; EN 61000-3-11			EN 61000-3-12; EN 61000-6-2; EN 61000-6-4; EN 61000-3-11		
Grid code		Grid code compatibility is always being upgraded, please contact SOCOMEC for grid code compatibility.					

Socomec: our innovations supporting your energy performance

1 independent manufacturer

3,200 employees
worldwide

10 % of sales revenue
dedicated to R&D

400 experts
dedicated to service provision

Your power management expert



POWER
SWITCHING



POWER
MONITORING



POWER
CONVERSION



EXPERT
SERVICES

The specialist for critical applications

- Control, command of LV facilities
- Safety of persons and assets
- Measurement of electrical parameters
- Energy management
- Energy quality
- Energy availability
- Energy storage
- Prevention and repairs
- Measurement and analysis
- Optimisation
- Consultancy, commissioning and training

A worldwide presence

8 production sites

- France (x3)
- Italy
- Tunisia
- India
- China (x2)

27 subsidiaries

- Australia • Belgium • China • France
- Germany • India • Italy • Netherlands
- Poland • Romania • Singapore
- Slovenia • Spain • Switzerland • Thailand
- Tunisia • Turkey • UK • USA

80 countries

where our brand is distributed

HEAD OFFICE

SOCOMEK GROUP

SAS SOCOMEK capital 10633100 €
R.C.S. Strasbourg B 548 500 149
B.P. 60010 - 1, rue de Westhouse
F-67235 Benfeld Cedex
Tel. +33 3 88 57 41 41 - Fax +33 3 88 57 78 78
info.scp.isd@socomec.com

YOUR DISTRIBUTOR / PARTNER



I0MSUNPCXX05 - EN 05 12.2020

www.socomec.com

