

Busbar supports

Busbars

Enclosures
& accessories

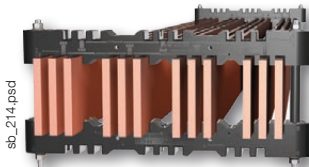

sb_214.psd

Fixed interphase, SB C 15

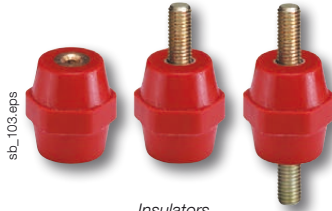

sb_103.eps

Insulators

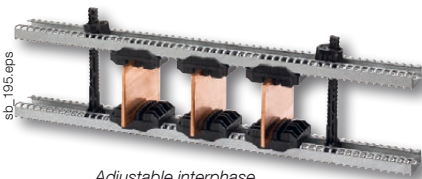

sb_195.eps

Adjustable interphase



sb_084.eps

Stair type support

The solution for

- > Electrical distribution



Conformity with standards

- > IEC 61439-1
- > IEC 60865-1



Approvals and certifications ⁽¹⁾

- > ASEFA/LCIE



(1) Product part numbers on request.

Function

SOCOMEK **insulating busbar supports** enable the fixing and holding in place of copper or aluminium busbars or busbar systems during a short-circuit.

Characteristics

Insulators

- Polyester without halogen.
- UL94 VO self-extinguishing.
- Colour red RAL 3002.
- Operating temperature from -40 °C to +130 °C.
- Deformation under load temperature (ASTM D643): > 200°C.
- Dielectric constant (ASTM D150): 4/5.
- Arc resistance (ASTM D495): > 180 s.
- Water absorption (ASTM D570): < 0.3%.

Busbar supports

- High dielectric strength.
- High mechanical resistance.
- Amagnetism of assembly parts.
- High resistance to damp heat (supplied "tropicalised").

Stair type supports

- Thermoplastic material.
- VO self-extinguishing.
- Insulating voltage: 1000 V.

Software tool for size selection

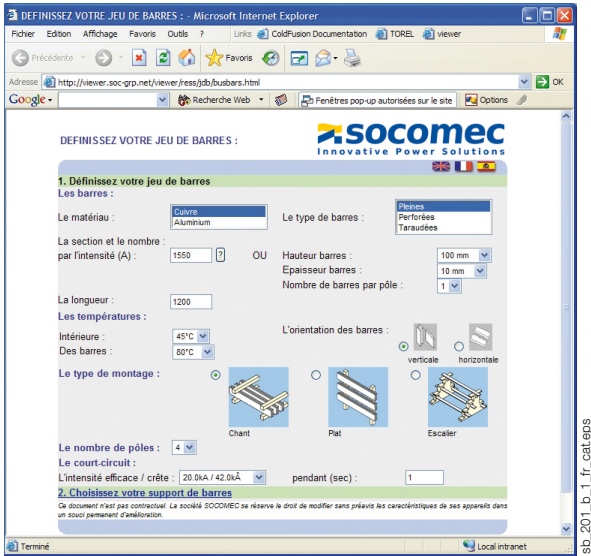

Strong points

- Easy to install and use
- Manages changes depending on environmental conditions

Function

Mechanical System is a multi-language software used for sizing busbar systems. It defines the configuration of the busbar system, including bar section and distance between supports, according to the required electrical characteristics of the panel in compliance with standard IEC 61439-1.

Advantages

Easy to install and use

The Mechanical System software is available for download from www.socomec.com. Once installed, the software can be used offline. It runs on Windows.

Manages changes depending on environmental conditions

Mechanical System allows you to perfectly adapt the copper section according to the environmental conditions of your panel and installation.



Busbar supports

Edgewise mounting with fixed interphase

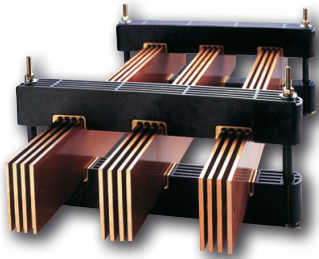

SBC 20

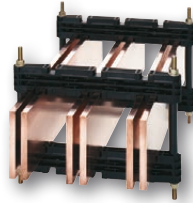

SB C 10

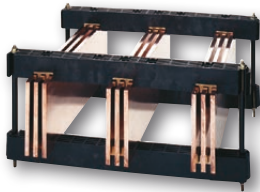

SB C 30

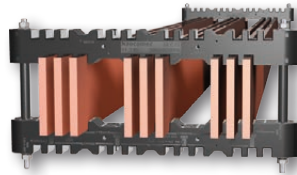

SB C 15

The solution for

- > Electrical distribution



Conformity with standards

- > IEC 61439-1
- > IEC 60865-1



Strong points

- > Insulating materials
- > Durability
- > Easy to use
- > Extensive range

Function

With SOCOMEC's insulating **bar supports** you can:

- mount and attach the busbars inside the electrical panel,
- cope with the forces experienced by the busbars during a short circuit.

Advantages

Insulating materials

- Our range of SB C edgewise mounting bar supports is made using thermoplastic. This very resistant material (reinforced fibreglass) is insulating so there are no risks in terms of clearance and creepage distances.

Durability

- Most bar supports have an M8 screw connection which provides outstanding robustness to the entire busbar structure.

Easy to use

- Only one type of spacer kit is required for the whole range of edgewise mounting busbar supports (SB C) with fixed interphase.

Extensive range

- Our range of bar supports allows you to assemble busbars with up to 120 kA of short-circuit current.

Selection guide

Edgewise mounting

- Busbar supports with **fixed interphase**

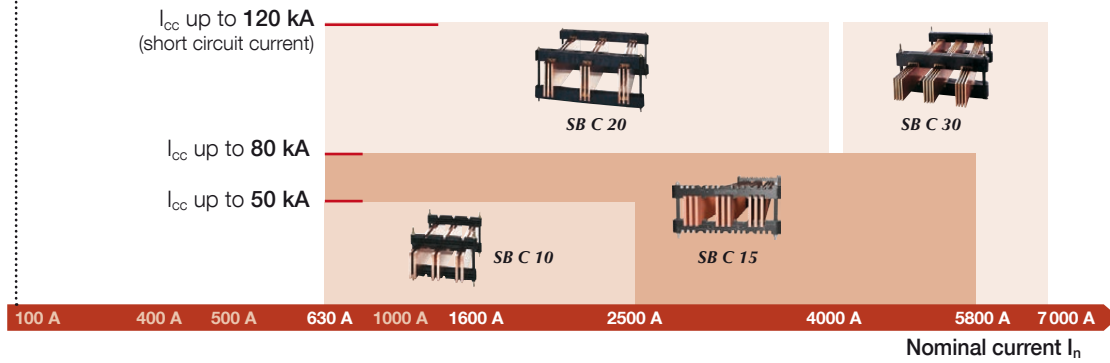

What you need to know

Bars joined by reversing a support
Compatible with SB C 10 and SB C 20

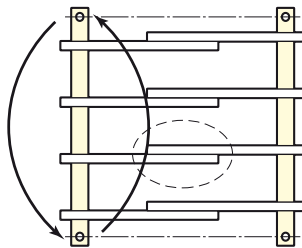

sb_045_b_1_x_cat.eps

Respecting the maximum distance between two supports ensures that the busbar supports are able to withstand the given short circuit current values. At these limits, distortion of the copper bars may occur. These deformations are permitted by standard IEC 61439-1 so long as they adhere to the insulation distances.

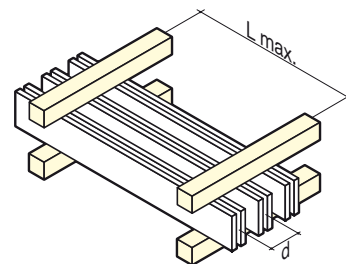

sb_021_b_1_x_cat.eps

Busbar supports

Edgewise mounting with fixed interphase

References

Support only

Use

To assemble a complete busbar support, please observe the multiple order quantity and order 1 spacer set

Type of busbar support	No. of poles	Number of busbars per phase	Thickness	Interphase	Interfixed	Available for order in multiples of	Support only Reference	
SB C 10	3 P	1 ... 2	5	75	250	2	5024 6300	
		1	10					
	4 P	1 ... 2	5	60			65	5024 6500
		1		75				5024 6400
	3 P	1	10	90			5024 6600	
	2	110						
SB C 15	3 P	1 ... 3	10	90	5024 4501			
	4 P			110				
SB C 20	3 P	1 ... 4	5	110	350	1	5024 8300	
				90			5024 8400	
	4 P	1 ... 3	10	110			5024 7300	
				90			5024 7400	
SB C 30	3 P	1 ... 3	10	185	525	5024 5300		
	4 P			130		5024 5500		

Spacer kit for support

Use

The spacer kit comprises 2 threaded rods and 2 insulating spacers cut at the length of the bar height as well as 4 nuts.

Bar height (mm)	Available for order in multiples of	Reference
25	1	5020 2025
30		5020 2030
32		5020 2032
40		5020 2040
50		5020 2050
60		5020 2060
63		5020 2063
80		5020 2080
100		5020 2100
125		5020 2125
160		5020 2160
200		5020 2200



Accessories

Adjustable interfixed profiles

Use

Adjustable interfixed profiles allow you to install the busbar supports at a variable depth. For high-load busbars, we recommend the use of adjustable reinforced floating profiles.

Type of busbar support	For depth Min./max. (mm)	Pack qty	Reference
SB C 10 2 x 5 / 1 x 10	575 / 675	1	5024 9050
SB C 10 1 x 10 / 2 x 10	575 / 775		5024 9051
SB C 15			5024 9052
SB C 20			5024 9054
SB C 30			

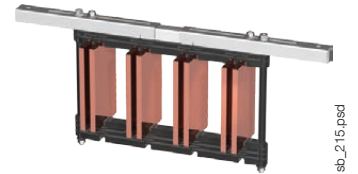

Adjustable reinforced floating profiles

Use

With adjustable reinforced floating profiles, you can install busbar supports in varying depths in the case of high-load busbars (from 100 kg/ml).

Type of busbar support	For depth Min./max. (mm)	Available for order in multiples of	Reference
SB C 15	575 / 775	1	5024 9053
SB C 20			5024 9055
SB C 30			

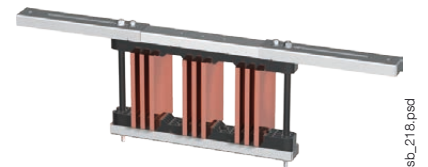

Holding rod for SB C 15

Use

With the holding rods for SB C 15, you can install the support on a standard mounting profile in the case of high-load busbars (from 100 kg/ml).

Material: Stainless steel threaded rod.

Bar height (mm)	Available for order in multiples of	Reference
32	1	5020 1040
40		5020 1060
50		5020 1101
60		
80		
100		5020 1125
125		5020 1160
160		



Busbar supports

Edgewise mounting with fixed interphase

Accessories (continued)

Bar holder

Use

The heels hold the busbars upright.

Type of busbar support	Number of bars	No. of poles	Available for order in multiples of	Reference
SBC 10	2 x 5 / 1 x 10	3	1	5024 9031
	2 x 5 / 1 x 10	4		5024 9041
	1 x 10 / 2 x 10	3		5024 9034
	1 x 10 / 2 x 10	4		5024 9044
SBC 15	1 to 3 x 10	3		5024 9032
	1 to 3 x 10	4		5024 9042
SBC 20	1 to 4 x 5 / 1 to 2 x 10	3		5024 9032
	1 to 4 x 5 / 1 to 2 x 10	4		5024 9042
SBC 30	1 to 3 x 10	3 / 4		5024 9033

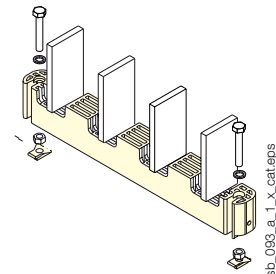

Installation corner piece

Use

Allows the holding heel to be placed on a support.

For cabinet Depth (mm)	To be ordered in multiples of	Reference
Min. 400	1	5024 9000
Min. 600	1	5024 9001

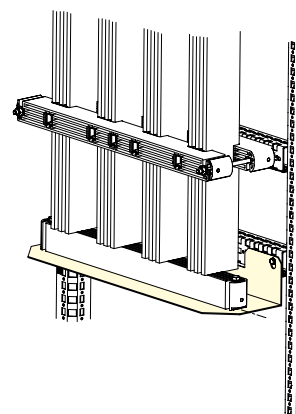

Fast connection of flexible bar or cables

Use

- Allows you to connect flexible bars or cables to busbars without having to drill the bars.
- Connect on 2x 10 mm-thick bars placed side by side, 10 mm apart.
- For lug or flexible bar widths greater than 40 mm, use 2 connection accessories.
- Tightening with M10 screw, tightening torque 45Nm.
- For the connection, you will need: 1 tightening head nut and 1 screw adapted to the height of the bars.

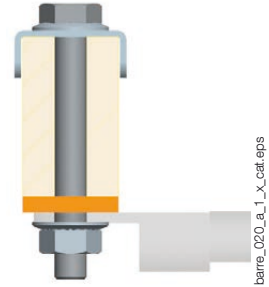

Type	Bar (mm)	Available for order in multiples of	Reference
M10 tightening head nut	All	12	5119 4423

Quick connection for busbars

Use

- Lock and connect busbars without drilling.
- Connect on 2x or 3x 10 mm-thick bars placed side by side.
- M10 screw tightening, 45 Nm torque. (to be ordered separately).

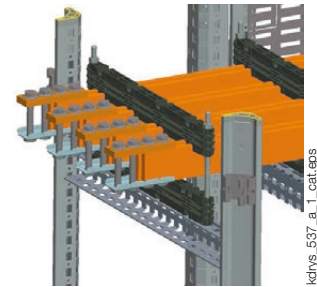

Current (A)	Number of bars / poles	Available for order in multiples of	Horizontal connection Reference	Vertical connection Reference
1600	2	1	5119 4411	5119 4401
3200	3		5119 4412	5119 4402
5000	3		5119 4413	5119 4403

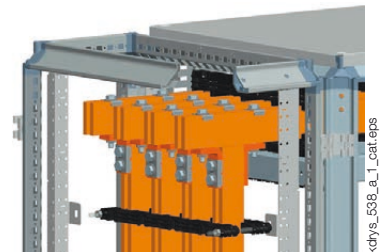

Screws for quick connection

Type	Bar (mm)	Available for order in multiples of	Reference
M10 screw	30	100	5119 4503
	50		5119 4505
	60		5119 4506
	80		5119 4508
	100		5119 4510
	125		5119 4512
	160	5119 4513	

Busbar supports

Edgewise mounting with fixed interphase

Characteristics

SB C 10

SB C 10 3 poles, distance between centres 75 mm, bar thickness 5 mm

	I_{cc} peak kA	25	48	63	84	110
	I_{cc} rms kA 1s	12.5	23	30	40	50
Bar width I	25	275	150	100	75	50
	32	300	150	125	75	75
	40	350	175	125	100	75
	50	400	200	150	125	75
	63	450	225	175	125	100
	80	500	250	200	150	125
	100	575	300	225	175	125
Bar width II	25	1000	650	500	375	300
	32	1000	750	575	425	350
	40	1000	850	650	475	375
	50	1000	950	725	550	350
	63	1000	1000	825	600	375
	80	1000	1000	950	625	400
	100	1000	1000	1000	650	425

SB C 10 3 poles, distance between centres 75 mm, bar thickness 10 mm

	I_{cc} peak kA	25	48	63	84	110
	I_{cc} rms kA 1s	12.5	23	30	40	50
Bar width I	30	800	425	325	225	175
	50	1000	550	425	300	225
	60	1000	600	450	325	275
	80	1000	700	550	400	325
	100	1000	800	600	450	350

SB C 10 3 poles, distance between centres 90 mm, bar thickness 10 mm

	I_{cc} peak kA	25	48	63	84	110
	I_{cc} rms kA 1s	12.5	23	30	40	50
Bar width I	30	825	425	325	250	200
	50	1000	550	425	300	250
	60	1000	625	475	350	275
	80	1000	1000	550	400	325
	100	1000	1000	625	450	375
Bar width II	30	1000	750	575	425	325
	50	1000	1000	750	550	375
	60	1000	1000	825	625	425
	80	1000	1000	975	725	450
	100	1000	1000	1000	825	450

SB C 10 4 poles, distance between centres 60 mm, bar thickness 5 mm

	I_{cc} peak kA	25	48	63	84	110
	I_{cc} rms kA 1s	12.5	23	30	40	50
Bar width I	25	275	150	100	75	50
	32	300	150	125	75	75
	40	350	175	125	100	75
	50	400	200	150	125	75
	63	450	225	175	125	100
	80	500	250	200	150	125
	100	575	300	225	175	125
Bar width II	25	1000	625	475	350	250
	32	1000	725	550	400	250
	40	1000	825	625	450	275
	50	1000	925	700	450	275
	63	1000	1000	800	475	300
	80	1000	1000	925	500	325
	100	1000	1000	1000	550	350

SB C 10 4 poles, distance between centres 65 mm, bar thickness 10 mm

	I_{cc} peak kA	25	48	63	84	110
	I_{cc} rms kA 1s	12.5	23	30	40	50
Bar width I	30	800	425	325	225	175
	50	1000	550	425	300	225
	60	1000	600	450	325	275
	80	1000	700	550	400	325
	100	1000	800	600	450	350

SB C 10 4 poles, distance between centres 90 mm, bar thickness 10 mm

	I_{cc} peak kA	25	48	63	84	110
	I_{cc} rms kA 1s	12.5	23	30	40	50
Bar width I	30	825	425	325	250	200
	50	1000	550	425	300	250
	60	1000	625	475	350	275
	80	1000	1000	550	400	325
	100	1000	1000	625	450	375
Bar width II	30	1000	750	575	425	325
	50	1000	1000	750	550	375
	60	1000	1000	825	625	425
	80	1000	1000	975	725	450
	100	1000	1000	1000	750	450

SB C 15

SB C 15 3 poles, distance between centres 110 mm, bar thickness 10 mm

	I_{cc} peak kA	84	110	154	165	176
	I_{cc} rms kA 1s	40	50	70	75	80
Bar width I	30	325	200	125	125	100
	50	425	250	175	150	150
	60	475	275	200	175	175
	80	550	325	225	200	200
	100	625	375	250	225	225
	125	700	400	275	250	250
	160	825	475	325	300	275
Bar width II	30	450	350	225	275	200
	50	575	475	325	275	250
	60	650	500	375	300	250
	80	750	600	375	325	250
	100	850	675	375	325	275
	125	975	775	400	350	300
	160	1000	925	425	375	325
Bar width III	30	625	475	350	300	250
	50	775	625	350	300	250
	60	1000	750	350	300	250
	80	1000	775	375	325	250
	100	1000	800	375	325	275
	125	1000	925	425	350	300
	160	1000	950	450	375	325

SB C1 5 4 poles, distance between centres 90 mm, bar thickness 10 mm

	I_{cc} peak kA	84	110	154	165	176
	I_{cc} rms kA 1s	40	50	70	75	80
Bar width I	30	275	225	125	125	100
	50	350	300	175	150	125
	60	375	350	175	175	150
	80	425	400	200	200	200
	100	475	450	250	225	225
	125	525	525	275	250	225
	160	625	600	325	300	275
	160	625	600	325	300	275
Bar width II	30	425	350	225	225	175
	50	575	450	275	225	200
	60	625	500	275	225	200
	80	725	575	275	250	225
	100	825	675	300	275	225
	125	950	750	350	300	225
	160	1000	825	400	325	275
	160	1000	825	400	325	275
Bar width III	30	575	475	275	225	200
	50	775	600	275	225	200
	60	850	600	275	225	200
	80	1000	650	275	250	225
	100	1000	675	300	275	225
	125	1000	750	350	300	250
	160	1000	825	400	325	275
	160	1000	825	400	325	275

SB C 20

SB C 20 3 poles, distance between centres 110 mm, thickness 10 mm

	I_{cc} peak kA	63	84	110	154	165	187	220	264
	I_{cc} rms kA 1s	30	40	50	70	75	85	100	120
Bar width I	50	775	575	475	325	300	250	225	175
	60	875	650	500	350	325	275	250	200
	80	1000	750	600	425	400	325	275	225
	100	1000	850	675	475	450	375	275	225
	125	1000	975	775	525	500	425	275	250
	160	1000	1000	875	600	575	500	300	250
Bar width II	50	1000	575	475	325	300	250	225	175
	60	1000	650	500	350	325	275	250	200
	80	1000	750	600	425	400	325	275	225
	100	1000	850	675	475	450	375	300	225
	125	1000	975	775	525	500	425	325	250
	160	1000	1000	875	600	575	500	350	250

SB C 20 4 poles, distance between centres 90 mm, thickness 10 mm

	I_{cc} peak kA	63	84	110	154	165	187	220	264
	I_{cc} rms kA 1s	30	40	50	70	75	85	100	120
Bar width I	50	750	550	450	300	275	225	225	150
	60	825	625	475	325	300	250	225	150
	80	975	725	575	400	375	300	250	175
	100	1000	825	650	450	425	350	275	175
	125	1000	950	750	500	475	400	300	200
	160	1000	1000	850	575	550	475	300	225
Bar width II	50	750	550	450	300	275	225	225	150
	60	825	625	475	325	300	250	225	150
	80	975	725	575	400	375	300	250	175
	100	1000	825	650	450	425	350	275	175
	125	1000	950	750	500	475	400	300	200
	160	1000	1000	850	575	550	475	300	225

Busbar supports

Edgewise mounting with fixed interphase

Characteristics (continued)

SB C 30

SB C 30 3 poles, distance between centres 185 mm, thickness 10 mm

	Icc peak kA	63	84	110	154	165	187	220	264
	Icc rms kA 1s	30	40	50	70	75	85	100	120
Bar width I	50	450	350	275	200	200	175	150	100
	60	500	375	300	225	200	175	150	125
	80	600	450	350	225	225	200	175	150
	100	650	500	400	275	250	225	200	175
	125	750	550	450	300	275	250	225	175
	160	825	625	500	350	300	275	250	200
	200	950	700	575	400	350	300	275	225
Bar width II	50	850	625	500	350	325	275	225	200
	60	925	700	550	375	350	300	250	225
	80	1000	800	650	450	400	350	300	250
	100	1000	925	725	500	450	400	350	275
	125	1000	1000	825	550	500	450	400	325
	160	1000	1000	925	625	575	525	450	375
	200	1000	1000	1000	700	650	575	500	375
Bar width III	50	1000	900	725	475	450	400	350	275
	60	1000	975	775	525	500	425	375	300
	80	1000	1000	925	625	575	500	425	350
	100	1000	1000	1000	700	650	575	475	350
	125	1000	1000	1000	800	725	650	550	375
	160	1000	1000	1000	900	825	750	575	375
	200	1000	1000	1000	1000	925	825	575	400

SB C 30 4 poles, distance between centres 130 mm, thickness 10 mm

	Icc peak kA	63	84	110	154	165	187	220	264
	Icc rms kA 1s	30	40	50	70	75	85	100	120
Bar width I	50	425	325	250	175	175	150	125	100
	60	475	350	275	200	175	150	125	100
	80	575	425	325	225	200	175	150	125
	100	625	475	375	250	225	200	175	150
	125	725	525	425	275	250	225	200	150
	160	800	600	475	325	275	250	225	175
	200	925	675	550	375	325	275	250	200
Bar width II	50	800	600	475	325	300	250	200	175
	60	850	650	525	350	325	275	225	200
	80	1000	775	600	425	375	325	275	225
	100	1000	875	675	475	425	375	325	250
	125	1000	975	775	525	475	425	375	275
	160	1000	1000	875	600	550	500	425	275
	200	1000	1000	1000	675	625	550	450	300
Bar width III	50	1000	825	650	425	400	375	325	225
	60	1000	900	725	475	450	400	325	225
	80	1000	1000	825	575	525	475	350	225
	100	1000	1000	950	650	600	525	375	250
	125	1000	1000	1000	750	575	575	425	275
	160	1000	1000	1000	850	775	600	425	275
	200	1000	1000	1000	975	825	625	450	275

Dimensions (mm)

SB C 10

2x 5 mm bar or 1x 10 mm bars

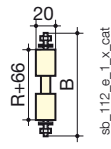
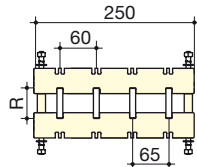
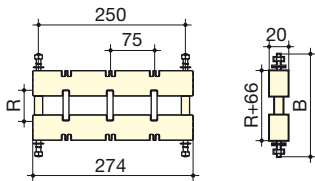

1 or 2 bars of 10 mm

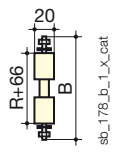
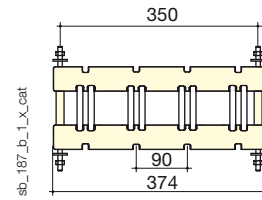
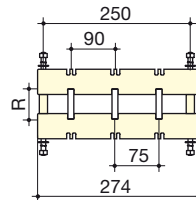

Fixed interphase:

- 3 poles 2 x 5 mm or 1 x 10 mm: 75 mm
- 4 poles bar thickness 5 mm: 60 mm, bar thickness 10 mm: 65 mm.

Fixed interphase:

- 3 poles 1 x 10 mm bar: 75 mm
2 x 10 mm bars per pole: 90 mm
- 4 poles 1 x or 2 x 10 mm bars: 90 mm.

SB C 15

3 poles 1 to 3x 10 mm bars

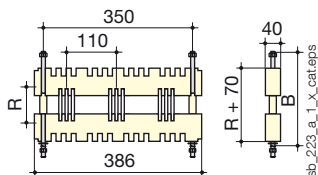

4 poles 1 to 3x 10 mm bars

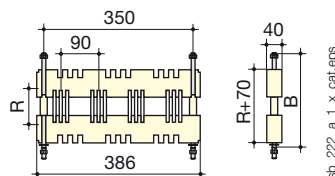

Fixed interphase:

- 3 poles: 110 mm
- 4 poles: 90 mm

SB C 20

3 poles 1 to 4x 5 mm bars and 1 to 2x 10 mm bars

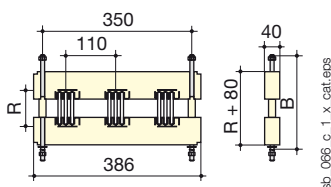

4 poles 1 to 4x 5 mm bars and 1 to 2x 10 mm bars

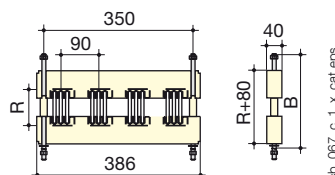

Fixed interphase:

- 3 poles: 110 mm
- 4 poles: 90 mm

SB C 30

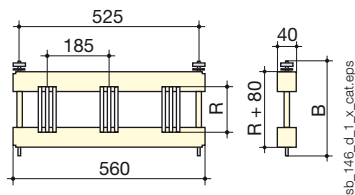
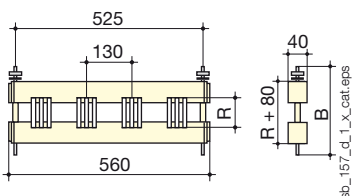

Fixed interphase:

- 3 poles: 185 mm
- 4 poles: 130 mm



Busbar supports

Edgewise mounting with adjustable interphase

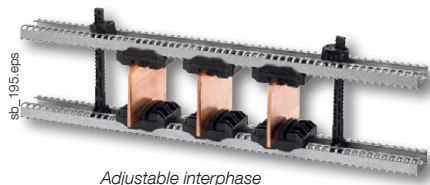

The solution for

- > Electrical distribution



Conformity with standards

- > IEC 61439-1
- > IEC 60865-1



Strong points

- > Insulating materials
- > Durability
- > Adaptability

Function

With SOCOMEC's insulating **bar supports** you can:

- mount and attach the busbars inside the electrical panel,
- cope with the forces experienced by the busbars during a short circuit.

Advantages

Insulating materials

Our range of SBC upright supports with adjustable interphase is made using thermoplastic. This very resistant material (reinforced fibreglass) is insulating so there are no risks in terms of clearance and creepage distances.

Amagnetism of assembly parts.

High resistance to damp heat (supplied "tropicalised").

Durability

Standard spacers are made of high-strength insulating material. If used in extreme conditions or for greater robustness, metal rod kits are available.

Adaptability

The studs are fixed onto profiles adapted to standard cabinet sizes.

Selection guide

Edgewise mounting

- Busbar supports with **adjustable interphase**

I_{cc} up to **80 kA**



SB C ER P



What you need to know

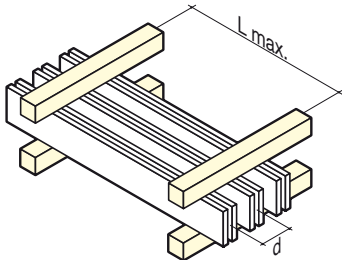

sb_021_b_1_x_cat.eps

Respecting the maximum distance between two supports ensures that the busbar supports are able to withstand the given short circuit current values. At these limits, distortion of the copper bars may occur. These deformations are permitted by standard IEC 61439-1 so long as they adhere to the insulation distances.

Busbar supports

Edgewise mounting with adjustable interphase

References

Full support

Designation	Thickness of busbar (mm)	Busbar width (mm)	Number of bars	No. of poles	Reference
Complete busbar supports	10	480	1 ... 3	4	5025 5135

Slot

Ordering guide

- For three poles, order: 6 x studs, 2 x rods, 2 x profiles.
- For four poles, order: 8 x studs, 2 x rods, 2 x profiles.

Slot	Bar thickness (mm)	Number of bars	No. of poles	Quantity	Available for order in multiples of	Reference
Slot for 5 mm bars	5	3	3 P	6 ⁽¹⁾	8	5025 5205
Slot for 5 mm bars	5	3	4 P	8 ⁽¹⁾	8	5025 5205
Slot for 10 mm bars	10	2	3 P	6 ⁽¹⁾	4	5025 5210
Slot for 10 mm bars	10	2	4 P	8 ⁽¹⁾	4	5025 5210
Slot for 10 mm bars	10	3	3 P	6 ⁽¹⁾	1	5025 5111
Slot for 10 mm bars	10	3	4 P	8 ⁽¹⁾	1	5025 5111

(1) Quantity required for 1 busbar support

(2) Kit of 2 profiles and 4 brackets.

Mounting accessories	Length (mm)	Quantity	Available for order in multiples of	Reference
Stud kit (bar height 25 to 200 mm)		2 ⁽¹⁾	4	5025 5100
Stud kit metal (bar height 0 to 100 mm)		2	2	5025 5101
Stud kit metal (bar height 0 to 200 mm)		2	2	5025 5102
380 mm profile	380	2 ⁽¹⁾	4	5025 5124
480 mm profile	480	2 ⁽¹⁾	4	5025 5125
580 mm profile	580	2 ⁽¹⁾	4	5025 5126
780 mm profile	780	2 ⁽¹⁾	4	5025 5128
2 m profile	2000		4	5025 5120
Profile for Prisma enclosure ⁽²⁾	525	1 ⁽¹⁾	1	5025 5130

Characteristics

5 mm slot / 3 bars and 10 mm slot / 2 bars

peak I _{sc}	L max. (support bars in mm) for					d min. (mm)	Iz (A) ⁽¹⁾
	82 kA	114 kA	152 kA	165 kA	187 kA		
rms I _{sc}	39 kA	52 kA	69 kA	75 kA	85 kA		
Bar x qty							
50 x 5 x 1	500	325	175	150		75	600
50 x 5 x 2	500	325	175	150	100	75	1050
50 x 5 x 3	500	325	175	150	100	75	1450
63 x 5 x 1	525	350	200	175		75	700
63 x 5 x 2	525	350	200	175	125	75	1250
63 x 5 x 3	525	350	200	175	125	75	1800
80 x 5 x 1	525	350	200	175	125	75	900
80 x 5 x 2	525	350	200	175	125	75	1550
80 x 5 x 3	525	350	200	175	125	75	2200
100 x 5 x 1	550	375	225	200	175	75	1100
100 x 5 x 2	550	375	225	200	175	75	1900
100 x 5 x 3	550	375	225	200	175	75	2650
125 x 5 x 1	575	400	250	225	200	75	1300
125 x 5 x 2	575	400	250	225	200	75	2350
125 x 5 x 3	575	400	250	225	200	75	3250
80 x 10 x 1	1000	750	350	300	200	75	1300
80 x 10 x 2	1000	750	350	300	200	75	2300
100 x 10 x 1	1000	750	375	325	225	75	1550
100 x 10 x 2	1000	775	375	325	225	75	2750
125 x 10 x 1	1000	775	375	325	225	75	1900
125 x 10 x 2	1000	775	375	325	225	75	3350
160 x 10 x 1	1000	775	400	350	250	75	2350
160 x 10 x 2	1000	800	400	350	250	75	4150

(1) Admissible busbar nominal current with a temperature inside the panel of between 45 °C and 80 °C.

For other mounting configurations, please contact us.

Characteristics (continued)

10 mm insert / 3 bars								
peak I_{sc}	L max. (bar supports in mm)						d (mm)	Iz (A) ⁽¹⁾
	63 kA	82 kA	114 kA	152 kA	165 kA	187 kA		
rms I_{sc}	30 kA	39 kA	52 kA	69 kA	75 kA	85 kA		
Bar x qty								
50 x 10 x 1	1000	1000	650	250	200	150	70	850
50 x 10 x 2	1000	1000	650	250	200	150	70	1550
50 x 10 x 3	1000	1000	650	250	200	150	70	2150
63 x 10 x 1	1000	1000	675	275	225	175	70	1050
63 x 10 x 2	1000	1000	675	275	225	175	70	1850
63 x 10 x 3	1000	1000	675	275	225	175	70	2600
80 x 10 x 1	1000	1000	700	300	250	175	70	1300
80 x 10 x 2	1000	1000	700	300	250	175	70	2300
80 x 10 x 3	1000	1000	700	300	250	175	70	3 200
100 x 10 x 1	1000	1000	725	325	275	175	70	1550
100 x 10 x 2	1000	1000	725	325	275	175	70	2750
100 x 10 x 3	1000	1000	725	325	275	175	70	3250
125 x 10 x 1	1000	1000	725	350	275	200	70	1900
125 x 10 x 2	1000	1000	725	350	275	200	70	3350
125 x 10 x 3	1000	1000	725	350	275	200	70	4650
160 x 10 x 1	1000	1000	750	350	300	200	70	2350
160 x 10 x 2	1000	1000	750	350	300	200	70	4150
160 x 10 x 3	1000	1000	750	350	300	200	70	5800

(1) Admissible busbar nominal current with a temperature inside the panel of between 45 °C and 80 °C
For other mounting configurations, please contact us.

Dimensions (mm)

Mounting

- 1 to 3 bars of 5 mm thickness, per pole.
- 1 to 3 bars of 10 mm thickness, per pole.
- Interphase distance: min. 70 mm and max. 200 mm.
- Use 2 studs positioned symmetrically on the extremity of the poles or between the outermost poles.

A (mm)	Cabinet (mm)
380	400
480	500
580	600
780	800

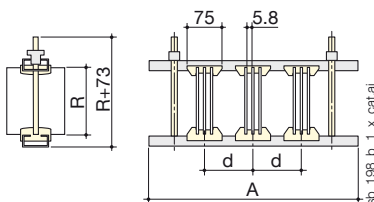

5 mm insert / 3 bars

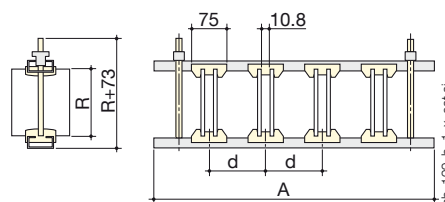

10 mm insert / 2 bars

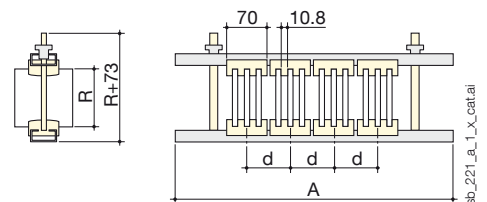

10 mm insert / 3 bars

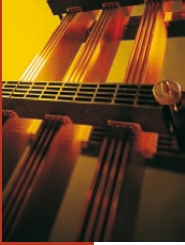

Busbar supports

Flat mounting with fixed interphase

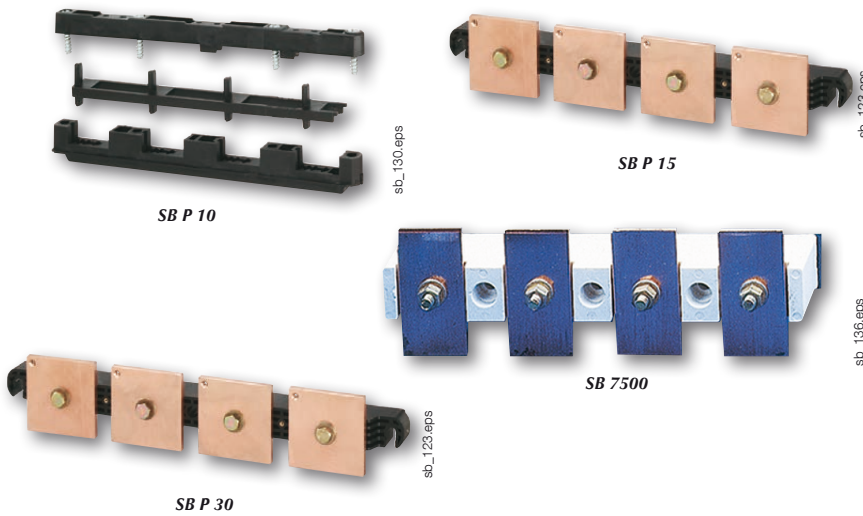

The solution for

- › Electrical distribution



Conformity with standards

- › IEC 61439-1
- › IEC 60865-1



Strong points

- › Insulating materials
- › Durability
- › Adaptability

Function

With SOCOMEC's insulating **bar supports** you can:

- mount and attach the busbars inside the electrical panel,
- cope with the forces experienced by the busbars during a short circuit.

Advantages

Insulating materials

Our range of SB P flat bar supports with fixed interphase is made using thermoplastic. This very resistant material (reinforced fibreglass) is insulating so there are no risks in terms of clearance and creepage distances.

Durability

Most bar supports have an M8 screw connection which provides outstanding robustness to the entire busbar structure.

Adaptability

The distance between the bar support attachment points is compatible with all commercially available enclosures.

Selection guide

Flat mounting

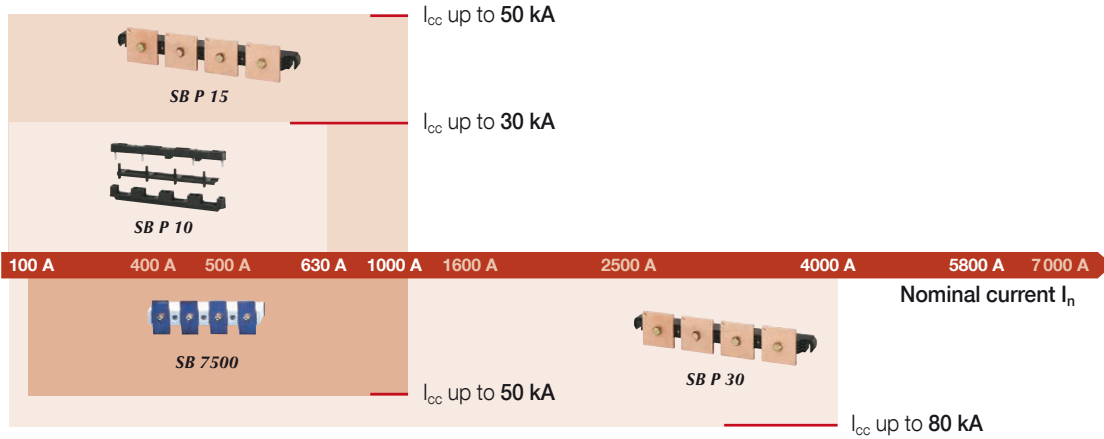

What you need to know

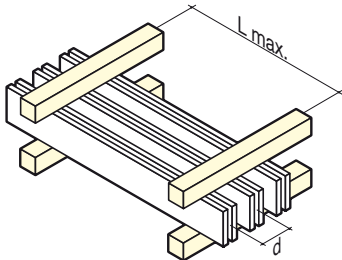

sb_021_b_1_x_cat.eps

Adhering to the maximum distance between two supports ensures that the busbar supports are able to withstand the given short circuit current values. At these limits, distortion of the copper bars may occur. These deformations are permitted by standard IEC 61439-1 so long as they adhere to the insulation distances.

Busbar supports

Flat mounting with fixed interphase

References

Support only

Bar support type	No. of poles	Insulation voltage (VAC)	Bar width (mm)	Pack qty	Reference
SB 7500	3 P	1000	40-50	1	5027 5310
SB 7500	4 P	1000	40-50	1	5027 5410
SB P 10	4 P	600	12-30	1	5026 0460
SB P 15	3 P / 4 P	1000	30 -80	1	5023 0150
SB P 30	3 P	1000	50-100	1	5023 0310
SB P 30	4 P	1000	50-80	1	5023 0410

Accessories

For SB P 15

Use

Mount the support and the bars to the support.

Fixing screws for support and bars	Available for order in multiples of	Reference
Fixing set	1	5023 0159

For SB P 30

Mounting bracket	Available for order in multiples of	Reference
2 mounting brackets	1	5024 9002

Bar fixing screws	Available for order in multiples of	Reference
Grub screws for mounting 1 bar	25	5119 4601
Headless screw for attaching 2 thicknesses of bar	25	5119 4602
Headless screw for attaching 3 thicknesses of bar	25	5119 4603



Characteristics

SB 7500

peak I_{sc}	L max. (support bars in mm) for						d (mm)	Iz (A)
	24 kA	48 kA	63 kA	82 kA	114 kA	152 kA		
rms I_{sc}	12 kA	23 kA	30 kA	39 kA	52 kA	69 kA		
Bar x qty							d (mm)	Iz (A)
50 x 5 x 1	1000	1000	950	725	525	450	75	600
50 x 5 x 2	1000	1000	1000	1000	975	850	75	1050

SB P 10

peak I_{sc}	L max. (support bars in mm) for					d min. (mm)	Iz (A)
	10 kA	15 kA	24 kA	48 kA	63 kA		
rms I_{sc}	6 kA	9 kA	12 kA	23 kA	30 kA		
Bar x qty						d min. (mm)	Iz (A)
12 x 5 x 1	1000	475	175			60	180
20 x 5 x 1	1000	1000	650	165		60	280
25 x 5 x 1	1000	1000	650	160		60	338
30 x 5 x 1	1000	1000	850	200	120	60	390
25 x 10 x 1	1000	1000	1000	250	150	60	508
30 x 10 x 1	1000	1000	1000	350	200	60	580

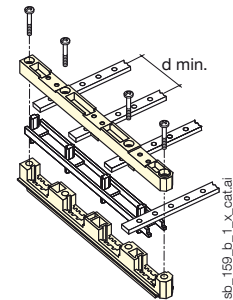

SB P 15

3 poles

peak I_{sc}	L max. (support bars in mm) for					d (mm)	Iz (A)
	24 kA	48 kA	63 kA	82 kA	114 kA		
rms I_{sc}	12 kA	23 kA	30 kA	39 kA	50 kA		
Bar x qty						d (mm)	Iz (A)
32 x 5 x 1	1000	1000	600	450	275	110	410
30 x 10 x 1	1000	1000	600	450	275	110	610
40 x 5 x 1	1000	1000	575	425	250	110	500
40 x 10 x 1	1000	1000	575	425	250	110	700
50 x 5 x 1	1000	1000	550	400	225	110	600
50 x 10 x 1	1000	1000	550	400	225	110	850
60 x 5 x 1	1000	1000	525	375	200	110	700
60 x 10 x 1	1000	1000	525	375	200	110	1000
80 x 5 x 1	1000	1000	500	350	175	110	900
80 x 10 x 1	1000	1000	500	350	175	110	1300

4 poles

peak I_{sc}	L max. (support bars in mm) for					d (mm)	Iz (A)
	24 kA	48 kA	63 kA	82 kA	114 kA		
rms I_{sc}	12 kA	23 kA	30 kA	39 kA	50 kA		
Bar x qty						d (mm)	Iz (A)
32 x 5 x 1	1000	1000	550	400	225	90	410
30 x 10 x 1	1000	1000	550	400	225	90	610
40 x 5 x 1	1000	1000	525	375	200	90	500
40 x 10 x 1	1000	1000	525	375	200	90	700
50 x 5 x 1	1000	1000	500	350	175	90	600
50 x 10 x 1	1000	1000	500	350	175	90	850
60 x 5 x 1	1000	1000	475	325	150	90	700
60 x 10 x 1	1000	1000	475	325	150	90	1000

Busbar supports

Flat mounting with fixed interphase

Characteristics (continued)

SB P 30

3 poles

peak I_{sc}	L max. (support bars in mm) for								d (mm)	Iz (A)
	63 kA	84 kA	110 kA	143 kA	165 kA	176 kA	187 kA	220 kA		
rms I_{sc}	30 kA	40 kA	50 kA	65 kA	75 kA	80 kA	85 kA	100 kA		
Bar x qty										
50 x 5 x 1	1000	950	525	300	225	200	175	130	123	600
63 x 5 x 1	1000	925	525	300	225	200	175	130	123	700
80 x 5 x 1	1000	900	500	300	225	175	175	125	123	900
80 x 5 x 2	1000	900	500	300	225	175	175	125	123	1550
50 x 10 x 1	1000	950	525	300	225	200	175	130	123	850
50 x 10 x 2	1000	975	525	300	225	200	175	135	123	1550
63 x 10 x 1	1000	925	525	300	225	200	175	130	123	1050
63 x 10 x 2	1000	950	525	300	225	200	175	130	123	1850
80 x 10 x 1	1000	900	500	300	225	175	175	125	123	1300
80 x 10 x 2	1000	925	500	300	225	200	175	125	123	2300
80 x 10 x 3	1000	950	525	300	225	200	175	130	123	3200

4 poles

peak I_{sc}	L max. (support bars in mm) for								d (mm)	Iz (A)
	63 kA	84 kA	110 kA	143 kA	165 kA	176 kA	187 kA	220 kA		
rms I_{sc}	30 kA	40 kA	50 kA	65 kA	75 kA	80 kA	85 kA	100 kA		
Bar x qty										
50 x 5 x 1	1000	1000	800	475	350	300	275	200	185	
63 x 5 x 1	1000	1000	800	475	350	300	275	200	185	
80 x 5 x 1	1000	1000	800	475	350	300	275	200	185	
80 x 5 x 2	1000	1000	800	475	350	300	275	200	185	
100 x 5 x 1	1000	1000	775	450	325	300	250	175	185	1100
100 x 5 x 2	1000	1000	775	450	325	300	250	175	185	1900
100 x 5 x 3	1000	1000	775	450	350	300	250	175	185	2650
50 x 10 x 1	1000	1000	800	475	350	300	275	200	185	
50 x 10 x 2	1000	1000	800	475	350	300	275	200	185	
63 x 10 x 1	1000	1000	800	475	350	300	275	200	185	
63 x 10 x 2	1000	1000	800	475	350	300	275	200	185	
80 x 10 x 1	1000	1000	800	475	350	300	275	200	185	
80 x 10 x 2	1000	1000	800	475	350	300	275	200	185	
80 x 10 x 3	1000	1000	800	475	350	300	275	200	185	
100 x 10 x 1	1000	1000	775	450	325	300	250	175	185	1550
100 x 10 x 2	1000	1000	775	450	350	300	250	175	185	2750
100 x 10 x 3	1000	1000	775	450	350	300	275	175	185	3850

Dimensions

SB 7500

No. of poles	A	B	C	J	R	T ₁	T ₂
3 P	220	38	35	75	52.5	11	6
4 P	295	38	35	75	52.5	11	6

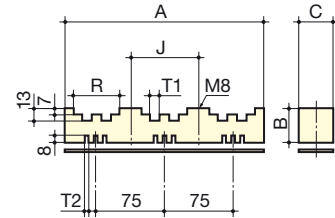

sb_149_a_1_x_cat

SB P 10

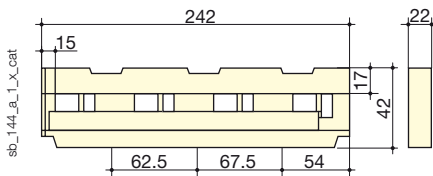

sb_144_a_1_x_cat

SB P 15

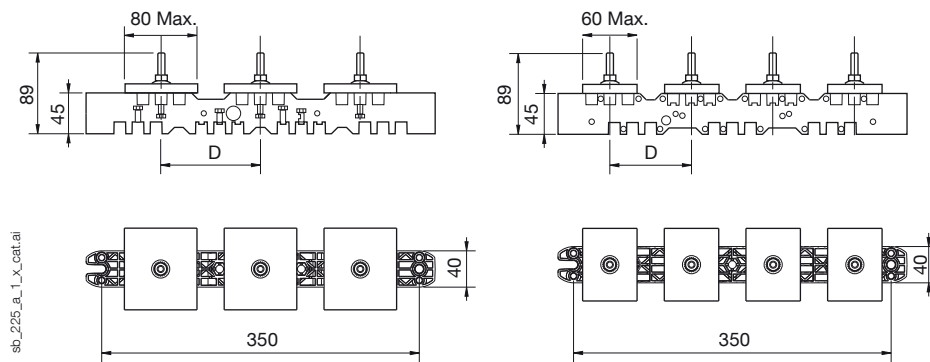

sb_225_a_1_x_cat.ai

SB P 30

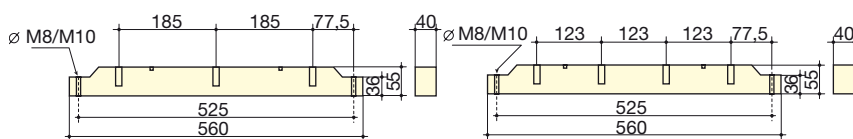

sb_154_c_1_x_cat

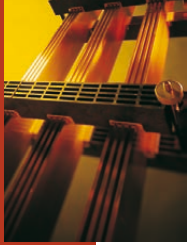

Busbar supports

Unipolar flat-mounted

Enclosures
& accessories



sb_104.eps

Hexagonal insulators



SB 205-206

sb_117.eps



SB 3

sb_118.eps



SB 1 - SB 2

sb_108.eps

The solution for

- › Electrical distribution



Conformity with standards

- › IEC 61439-1
- › IEC 60865-1



Strong points

- › Insulating materials
- › Durability
- › Adaptability

sb_136.eps

Function

With SOCOMEC's insulating **bar supports** you can:

- mount and attach the busbars inside the electrical panel,
- cope with the forces experienced by the busbars during a short circuit.

Advantages

Insulating materials

Our range of SB P flat busbar supports with fixed interphase is made from insulating materials. This material poses no risks in terms of clearance and creepage distances.

Durability

Most bar supports have an M8 screw connection which provides outstanding robustness to the entire busbar structure.

Adaptability

The distance between the bar support attachment points is compatible with all commercially available enclosures.

Selection guide

Flat mounting



What you need to know

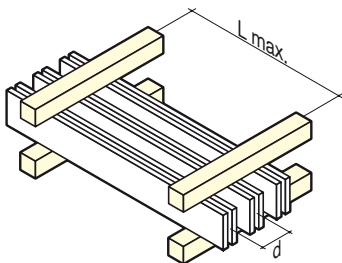

sb_021_b_l_x_catsps

Adhering to the maximum distance between two supports ensures that the busbar supports are able to withstand the given short circuit current values. At these limits, distortion of the copper bars may occur. These deformations are permitted by standard IEC 61439-1 so long as they adhere to the insulation distances.

Busbar supports

Unipolar flat-mounted

References

Hexagonal insulator

Height H (mm)	Thread M	Available for order in multiples of	Female-female Reference	Male-female Reference	Male-male Reference
16	M4	10	-	5038 1604	5039 1604
16	M5	10	-	5038 1605	5039 1605
20	M4	10	5031 2004	-	-
20	M6	10	5031 2006	-	-
25	M5	10	-	5038 2505	5039 2505
25	M6	10	5031 2506	5038 2506	5039 2506
30	M6	10	5031 3006	-	-
30	M8	10	5031 3008	-	-
35	M6	10	5031 3506	-	-
35	M8	10	5031 3508	5038 3508	5039 3508
35	M10	10	5031 3510	5038 3510	5039 3510
40	M8	10	5031 4008	-	-
40	M10	10	5031 4010	-	-
45	M8	10	5031 4508	-	-
45	M10	10	5031 4510	-	-
50	M8	10	5031 5008	5038 5008	5039 5008
50	M10	10	5031 5010	5038 5010	5039 5010
50	M12	10	5031 5012	-	-
60	M10	10	5031 6010	5038 6010	5039 6010
65	M10	10	5031 6510	-	-
70	M12	10	5031 7012	-	-

Support type SB

Support type	Insulation voltage (VAC)	Number of bars	Bar width (mm)	Available for order in multiples of	Reference
SB 1	690	1	20-25	6	5021 0110
SB 2	690	1	32-40	6	5022 0110
SB 3 without screws	690	1 ... 2	32-63	6	5023 0111
SB 3 pre-assembled (1)	690	1 ... 2	32-63	6	5023 0110
SB 205	1000	1 ... 3	100	6	5022 5110
SB 306	1000	1 ... 3	160	6	5023 6110

Accessories

Grub screw

Length (mm)	Thread	To be ordered in multiples of	Reference
20	M6	20	5032 2006
20	M8	20	5032 2008
25	M6	20	5032 2506
25	M8	20	5032 2508
30	M6	20	5032 3006
30	M8	20	5032 3008
40	M8	20	5032 4008
40	M10	20	5032 4010
50	M12	20	5032 5012



sb_121_eps

Characteristics

Hexagonal insulator

Height H (mm)	Threading M	Rated voltage (V) AC/DC	Insulation voltage (VAC)		Mechanical characteristics (daN)		Max. tightening torque (Nm)
			50 Hz 1 min	Peak	Flexion	Traction	
16	M4	500	3000	5500	100	150	3
16	M5	500	3000	5500	100	150	6
20	M4	500	3000	5500	70	170	9
20	M6	500	3000	5500	100	190	8
25	M5	500	3000	5500	180	400	6
25	M6	500	3000	5500	170	370	12
30	M6	1000	6000	11000	200	650	22
30	M8	1000	6000	11000	360	800	40
35	M6	1400	9000	16000	230	720	25
35	M8	1400	9000	16000	380	900	42
35	M10	1400	9000	16000	320	800	44
40	M8	2000	12000	21500	620	1200	50
40	M10	2000	12000	21500	620	1100	60
45	M8	2000	12000	21500	550	1200	55
45	M10	2000	12000	21500	550	1100	65
50	M8	2000	12000	21500	650	1800	60
50	M10	2000	12000	21500	650	1700	70
50	M12	2000	12000	21500	660	1300	130
60	M10	2400	12000	27000	560	1600	85
65	M10	2400	12000	27000	750	1600	90
70	M12	2400	12000	27000	750	1500	135

Busbar supports

Unipolar flat-mounted

Characteristics (continued)

Hexagonal insulator

General characteristics

Height H (mm)	Threading	Bar x qty	L max. (support bars in mm) for					d min. (mm)	Iz (A) ⁽¹⁾	
			peak I _{sc}	24 kA	48 kA	63 kA	82 kA			114 kA
			rms I _{sc}	12 kA	23 kA	30 kA	39 kA			52 kA
20	M4	15 x 5 x 1	400	100				45	220	
20	M4	20 x 5 x 1	400	100				45	280	
25	M6	15 x 5 x 1	550	135				45	220	
25	M6	20 x 5 x 1	525	135				45	280	
25	M6	25 x 5 x 1	575	145				50	330	
30	M6	15 x 5 x 1	675	165				45	220	
30	M6	20 x 5 x 1	650	165				45	280	
30	M6	25 x 5 x 1	725	175	105			50	330	
30	M8	15 x 5 x 1	850	250	155			45	220	
30	M8	20 x 5 x 1	1000	250	155			45	280	
30	M8	25 x 5 x 1	1000	275	170	100		50	330	
35	M6	15 x 5 x 1	700	175	100			45	220	
35	M6	20 x 5 x 1	675	170	100			45	280	
35	M6	25 x 5 x 1	750	175	110			50	330	
35	M8	15 x 5 x 1	850	275	160			45	220	
35	M8	20 x 5 x 1	1000	275	160			45	280	
35	M8	25 x 5 x 1	1000	300	175	105		50	330	
35	M8	32 x 5 x 1	1000	325	175	110		55	410	
35	M10	20 x 5 x 1	850	200	125			45	280	
35	M10	25 x 5 x 1	950	225	135			50	330	
35	M10	32 x 5 x 1	1000	250	150			55	410	
40	M8	20 x 5 x 1	1000	325	175	110		45	280	
40	M8	25 x 5 x 1	1000	350	200	125		50	330	
40	M8	32 x 5 x 1	1000	375	225	135		55	410	
40	M10	20 x 5 x 1	1000	325	175	110		45	280	
40	M10	25 x 5 x 1	1000	350	200	125		50	330	
40	M10	32 x 5 x 1	1000	375	225	135		55	410	
45	M8	25 x 5 x 1	1000	425	250	150		50	330	
45	M8	32 x 5 x 1	1000	475	175	160		55	410	
45	M8	50 x 5 x 1	1000	625	350	200	110	75	600	
45	M10	25 x 5 x 1	1000	425	250	145		50	330	
45	M10	32 x 5 x 1	1000	450	250	160		55	410	
45	M10	50 x 5 x 1	1000	600	350	200	110	75	600	
50	M8	25 x 5 x 1	1000	450	250	155		50	330	
50	M8	32 x 5 x 1	1000	475	275	170		55	410	
50	M8	50 x 5 x 1	1000	650	375	225	115	75	600	
50	M10	32 x 5 x 1	1000	525	300	175		55	410	
50	M10	50 x 5 x 1	1000	700	400	225	125	75	600	
60	M10	50 x 5 x 1	1000	700	400	225	125	75	600	
65	M10	50 x 5 x 1	1000	775	450	250	135	75	600	

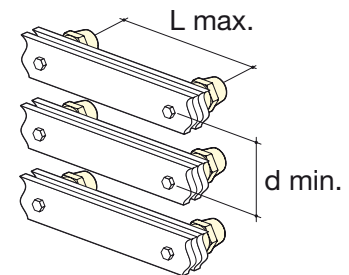

sb_164_a_1_x_cat

(1) Admissible busbar nominal current with a temperature inside the panel of between 45°C and 80°C.
For other mounting configurations, please contact us.

SB 1 - SB 2

Support	Bar x qty	L max. (support bars in mm) for					d min. (mm)	Iz (A) ⁽¹⁾	
		peak I _{sc}	24 kA	48 kA	63 kA	82 kA			114 kA
		rms I _{sc}	12 kA	23 kA	30 kA	39 kA			52 kA
SB 1	20 x 3 x 1	650	325	250	175	135	50	210	
SB 1	20 x 5 x 1	850	425	325	250	175	50	280	
SB 1	25 x 5 x 1	1000	525	400	300	200	50	330	
SB 2	32 x 5 x 1	1000	750	575	450	300	70	410	
SB 2	40 x 5 x 1	1000	950	700	550	400	70	500	

(1) Admissible busbar nominal current with a temperature inside the panel of between 45°C and 80°C.
For other mounting configurations, please contact us.

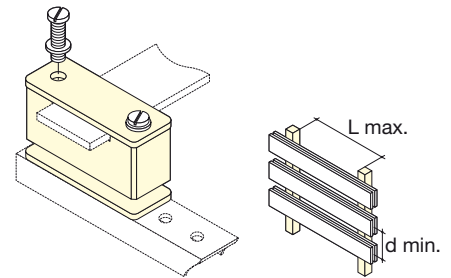

sb_150_a_1_x_cat

SB 3

Support	Bar x qty	L max. (support bars in mm) for					d min. (mm)	Iz (A) ⁽¹⁾	
		peak I _{sc}	24 kA	48 kA	63 kA	82 kA			114 kA
		rms I _{sc}	12 kA	23 kA	30 kA	39 kA			52 kA
	32 x 5 x 2	1000	1000	925	700	500	70	580	
	40 x 5 x 2	1000	1000	1000	1000	1000	70	700	
	50 x 5 x 2	1000	1000	1000	925	675	75	850	
	63 x 5 x 2	1000	1000	1000	1000	1000	85	1000	

(1) Admissible busbar nominal current with a temperature inside the panel of between 45°C and 80°C.
For other mounting configurations, please contact us.

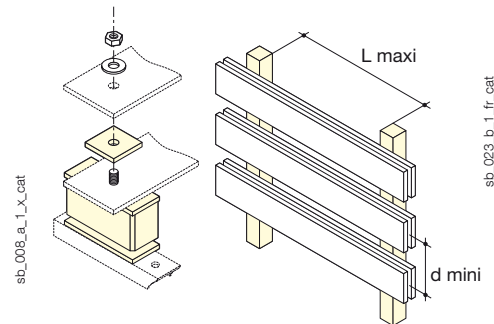

sb_008_a_1_x_cat

sb_023_b_1_fr_cat

SB 205 - SB 206

Support	Bar x qty	L max. (support bars in mm) for						d min. (mm)	Iz (A)	
		peak I _{sc}	48 kA	63 kA	82 kA	114 kA	152 kA			165 kA
		rms I _{sc}	12.5 kA	23 kA	30 kA	40 kA	50 kA			75 kA
SB 205	100 x 10 x 1	1000	800	475	250	150	125	125	1550	
SB 205	100 x 10 x 2	1000	800	475	250	150	125	125	2750	
SB 205	100 x 10 x 3	1000	800	475	250	150	125	125	3850	
SB 306	160 x 10 x 1	1000	1000	625	350	200	150	175	2350	
SB 306	160 x 10 x 2	1000	1000	625	350	200	150	175	4150	
SB 306	160 x 10 x 3	1000	1000	625	350	200	150	175	5800	

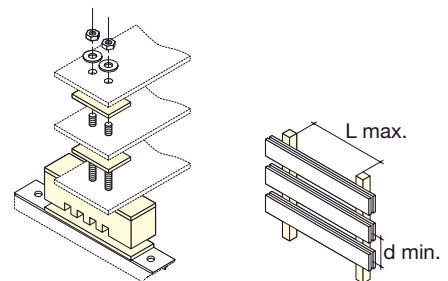

sb_152_a_1_x_cat

Busbar supports

Unipolar flat-mounted

Dimensions

Hexagonal insulator

Height H (mm)	Threading M	Depth		Diameter E (mm)	Length	
		D (mm)	Pu (mm)		W (mm)	L1 (mm)
16	M4	6	5	14	26	36
16	M5	6	5	14	26	36
20	M4	8	5.5	19	-	-
20	M6	8	5.5	19	-	-
25	M5				35	45
25	M6	10	7	25	35	45
30	M6	10	7	33	-	-
30	M8	12	9	33	-	-
35	M6	12	9	33	-	-
35	M8	12	9	33	50	65
35	M10	12	9	33	65	95
40	M8	15	12	40	-	-
40	M10	15	12	40	-	-
45	M8	15	12	41	-	-
45	M10	15	12	41	-	-
50	M8	20	17	46	75	100
50	M10	20	17	46	80	110
50	M12	20	17	46	-	-
60	M10	20	17	50	85	110
65	M10	20	17	55	-	-
70	M12	25	21	55	-	-

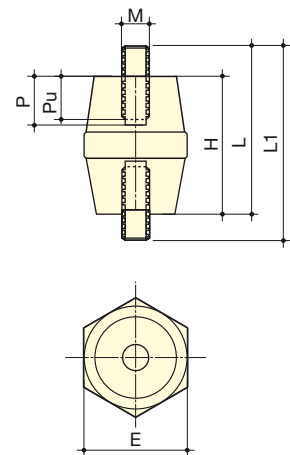

sb_224_a_1_fr_cat.eps

SB 1 – SB 2

Support	A	B	C	J
SB 1	50	23	20	34
SB 2	68	23	23.5	50

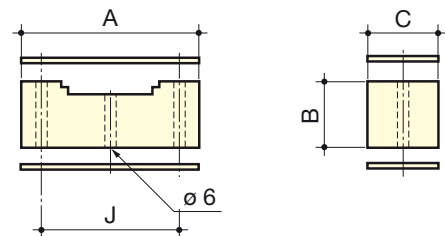

sb_014_c_1_fr_cat

SB 3

Support	A	B	C	J
SB 3 without screws	65	32	28	36
SB 3 with screws	65	32	28	36

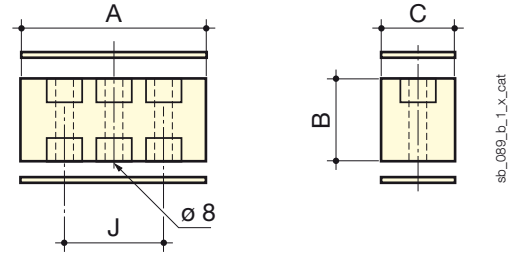

Dimensions

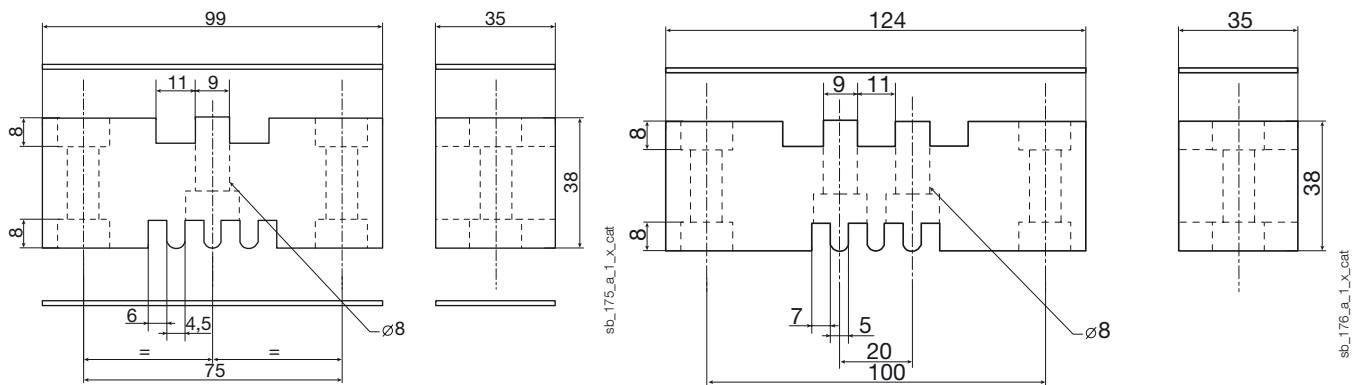

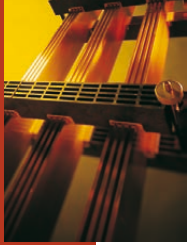

Busbar supports

Other supports

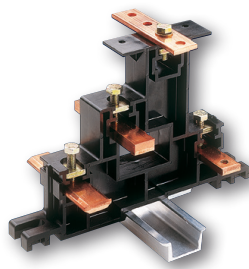

SB E 44

sb_038.eps

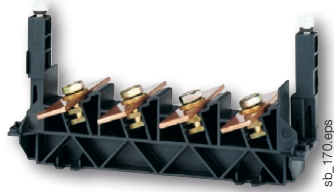

SB P 44

sb_170.eps

The solution for

- > Electrical distribution



Conformity with standards

- > IEC 61439-1
- > IEC 60865-1



Strong points

- > Insulating materials
- > Durability
- > Adaptability

Function

With SOCOMEC's insulating **bar supports** you can:

- mount and attach the busbars inside the electrical panel,
- cope with the forces experienced by the busbars during a short circuit.

Advantages

Insulating materials

Our range of busbar supports is made using thermoplastic. This very resistant material (reinforced fibreglass) is insulating so there are no risks in terms of clearance and creepage distances.

Durability

Most bar supports have an M8 screw connection which provides outstanding robustness to the entire busbar structure.

Adaptability

The distance between the bar support attachment points is compatible with all commercially available enclosures.

References

SB E 44 and SB P 44

Type of busbar support	Insulation voltage (VAC)	No. of poles	Bar width (mm)	Pack qty	Reference
SB E 44	690	4 P	15-32	1	5028 0410
SB P 44	690	4 P	20-32	1	5026 0450
Designation of SBE 44 accessories				Pack qty	Reference
270 mm long cap protection kit				1	5028 0411
420 mm long cap protection kit				1	5026 0412
620 mm long cap protection kit				1	5028 0413
Set of 20 protection screen adaption spacers				1	5026 0415

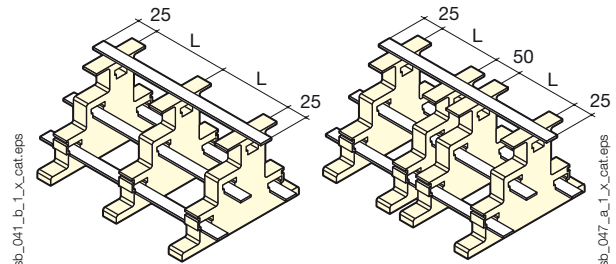

Type 1: Busbars including 3 (or more) equally spaced SB E 44 supports.

Type 2: Busbars including 3 (or more) SB E 44 supports with doubled intermediary supports.

Characteristics

SB E 44

Support	Bar x qty	L max. (support bars in mm) for						Iz (A) ⁽¹⁾	
		peak I _{sc}	10 kA	15 kA	24 kA	38 kA	48 kA		63 kA
		rms I _{sc}	6 kA	9 kA	12 kA	19 kA	23 kA		30 kA
Type 1	15 x 3 x 1	950	625	400	250	175		160	
Type 1	15 x 5 x 1	1000	825	500	300	175		220	
Type 1	15 x 6 x 1	1000	900	550	300	200		250	
Type 1	15 x 8 x 1	1000	1000	650	300	200		290	
Type 1	20 x 3 x 1	1000	825	525	300	175		210	
Type 1	20 x 5 x 1	1000	1000	675	300	175		280	
Type 1	20 x 6 x 1	1000	1000	750	300	175		310	
Type 1	20 x 8 x 1	1000	1000	775	300	175		370	
Type 1	32 x 5 x 1	1000	1000	675	250	170		410	
Type 1	32 x 6 x 1	1000	1000	675	250	170		460	
Type 2	15 x 3 x 1	950	625	400	250	200	150	160	
Type 2	15 x 5 x 1	1000	825	500	325	250	175	220	
Type 2	15 x 6 x 1	1000	900	550	350	275	200	250	
Type 2	15 x 8 x 1	1000	1000	650	400	325	225	290	
Type 2	20 x 3 x 1	1000	825	525	325	250	200	210	
Type 2	20 x 5 x 1	1000	1000	675	425	325	225	280	
Type 2	20 x 6 x 1	1000	1000	750	450	375	225	310	
Type 2	20 x 8 x 1	1000	1000	850	525	375	225	370	
Type 2	32 x 5 x 1	1000	1000	1000	525	325	175	410	
Type 2	32 x 6 x 1	1000	1000	1000	525	325	175	460	

SB P 44

peak I _{sc}	L max. (support bars in mm) for						d min. (mm)	Iz (A)
	10 kA	15 kA	24 kA	48 kA	63 kA	82 kA		
rms I _{sc}	6 kA	9 kA	12 kA	23 kA	30 kA	39 kA		
Bar x qty								
20 x 5 x 1	1000	1000	800	350	200	125	50	280
25 x 5 x 1	1000	1000	1000	350	200	125	50	330
32 x 5 x 1	1000	1000	1000	350	200	120	50	390
25 x 10 x 1	1000	1000	1000	350	200	125	50	500
30 x 10 x 1	1000	1000	1000	350	200	120	50	580
32 x 10 x 1	1000	1000	1000	350	200	120	50	610

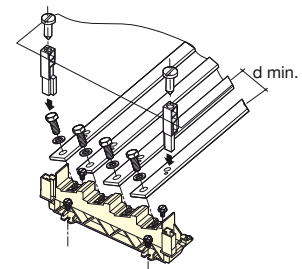

sb_165_c_1_x_cat

Dimensions (mm)

SB E 44

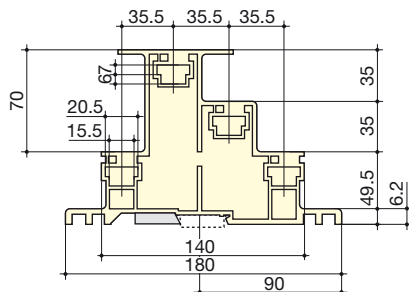

sb_036_e_1_x_cat

SB P 44

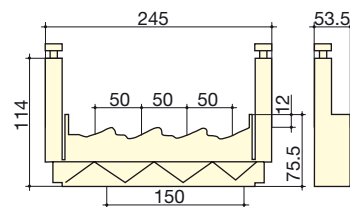

sb_147_b_1_x_cat